

# RADIANT

ARCHITECTURAL LIGHTING

2023

# RADIANT

Established in 2008 in London, Radiant Architectural Lighting provides innovative LED lighting solutions for important projects around the world.

Innovation is at the heart of Radiant.

Bespoke custom-built products are what we do best, with many of today's 'standard' products originating from customised project requests.

All Radiant systems are made to order and are designed in the UK. Up to this point, all production has been in the UK. We are working with key local partners to investigate optimal ways to produce close to project locations, minimising transport and logistics carbon emissions, while maintaining our high-quality standards.

Radiant Architectural Lighting systems are designed to fit into a circular economy model and can be refurbished and rebuilt many times.

Radiant products are designed for flexibility, adjustability, maintainability, sustainability, and performance, whilst embracing the latest lighting technologies and processes to deliver longer lasting and efficient lighting systems for any architectural application.

With a strong heritage in luminaire design, Radiant excels in designing products for both interior and exterior application areas, to give lighting designers the perfect tools to illuminate and enhance the built space beautifully.

Radiant has worked with leading lighting designers and architects on a plethora of high-profile global projects including the award-winning Strasbourg Cathedral, the Zaha Hadid-designed Heydar Aliyev Centre, Burberry, The Ritz Hotel Paris, Harrods, Dior stores and the Foster + Partners designed Dorchester Hotel in Dubai as well as the Lusail Plaza Towers in Qatar.

# Guide

## Linear Lighting



### 3D LED Flex Systems

Page 4 - 7	3D LED Flex System Overview
Page 8 - 9	Circular economy approach
Page 10 - 11	3D LED Flex 200 System IP66
Page 12 - 17	3D LED Flex 100 System IP20 & IP66
Page 18 - 33	3D LED Flex 40 System IP20, IP66 & IP68
Page 34 - 39	3D LED Flex 25 System IP20, IP66 & IP68



### Other flexible linear systems

Page 40 - 45	Centura System IP20
Page 46 - 47	Serpentine System IP65
Page 58 - 59	Euclid 20 Balljoint System IP20



### Linear systems

Page 48 - 49	F Grazer System IP20
Page 50 - 51	Shard System IP20
Page 52-53	Flaplight System IP20
Page 54	Flaplight Micro & Nano
Page 55	Euclid 12 System IP20
Page 56 - 57	Euclid 20 System IP20
Page 60 - 63	Euclid 30 System IP65 & IP68
Page 64 - 71	Euclid 40 System IP20 & IP65
Page 72 - 73	Euclid 60 System IP65
Page 74 - 77	Euclid 60 In-Ground System IP68
Page 78 - 79	Euclid 80 System IP65
Page 80 - 81	Euclid 100 System IP65
Page 82 - 83	Light Pipe System IP20

## Accent lighting



Page 84 - 87	Micro Track System
Page 88	Micro Egg Pendant System
Page 89	Nano, Micro & Macro Ribbed Pendant System
Page 90 - 91	Magnetic Low Voltage Track System
Page 92 - 93	Global Track System
Page 94 - 97	D100 Spotlight System IP20
Page 98 - 101	D100 Spotlight System IP65
Page 102 - 103	D40 Spotlight System IP65
Page 104 - 105	Centura Module System IP20

## Effect lighting



Page 106 - 107	RAD 250 IP68
Page 108 - 111	Water Effect System IP20 & IP65
Page 112	Water Effect In-Ground System IP65, and IP67
Page 113	Water Effect Linear System IP20, IP66 & IP67

Page 84 - 87	Micro Track System
Page 88	Micro Egg Pendant System
Page 89	Nano, Micro & Macro Ribbed Pendant System
Page 90 - 91	Magnetic Low Voltage Track System
Page 92 - 93	Global Track System
Page 94 - 97	D100 Spotlight System IP20
Page 98 - 101	D100 Spotlight System IP65
Page 102 - 103	D40 Spotlight System IP65
Page 104 - 105	Centura Module System IP20

Page 106 - 107	RAD 250 IP68
Page 108 - 111	Water Effect System IP20 & IP65
Page 112	Water Effect In-Ground System IP65, and IP67
Page 113	Water Effect Linear System IP20, IP66 & IP67

# 3D LED Flex Range

## Modular + Linear + 3D Flexible

The multi-award winning 3D LED Flex system has developed from a custom solution for a Zaha Hadid designed building into a comprehensive modular linear lighting system with a vast range of options.

Ideal for use in a wide range of interior, exterior and underwater lighting projects where curved lines of light are needed to illuminate non-linear building surfaces, columns and domes.

The patented mechanical joint structure allows the individual modules to be bent and twisted in three dimensions to follow the most complex building contours.

- Flexible in 3 Dimensions & hand-bendable and lockable on-site
- Four sizes, for projects of all sizes. Up to 12,000 lumens per mtr from the 200 size down to 4,000 lumens per mtr from the 25.
- IP ratings of IP20, IP44, IP65, IP66 and IP68 submersible
- A wide range of LED light engine, reflector and lens options available. White light, RGB, RGBW, and dynamic white options available
- Wide range of bracketry and anti-glare accessories. Custom lengths up to 2.5 mtrs based on a 100mm or 200mm module length

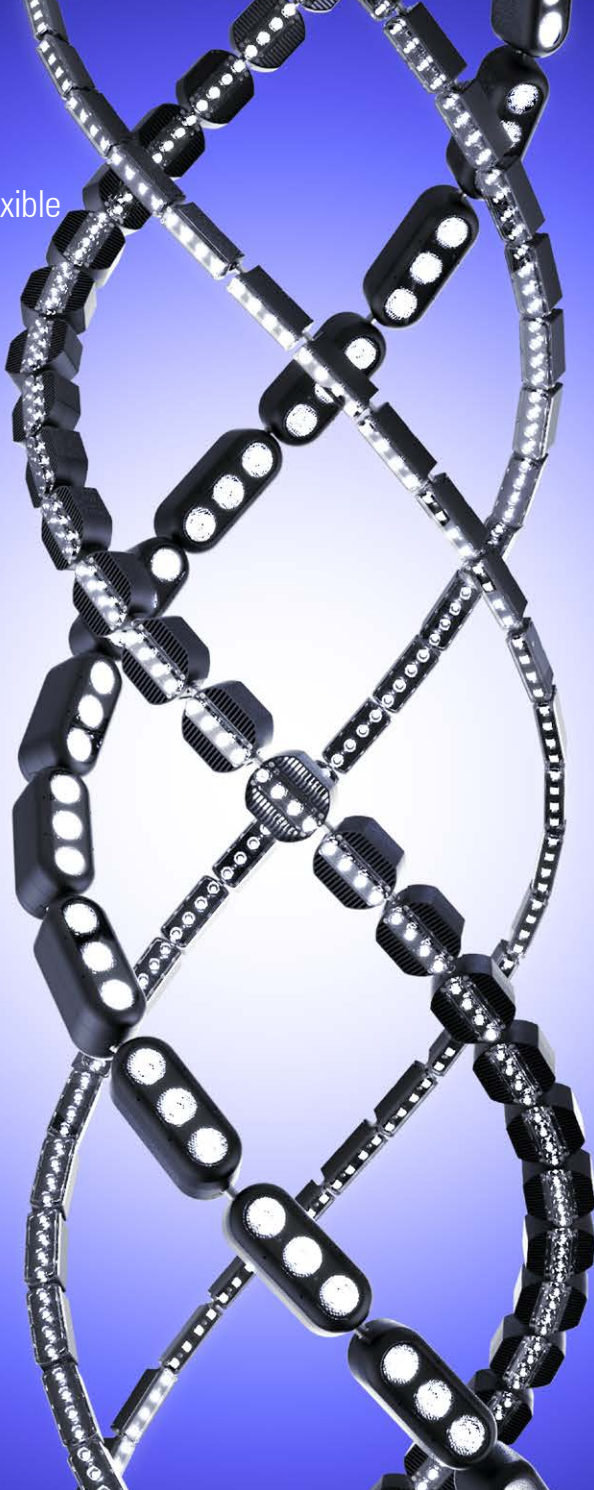

## 3D LED Flex 200

- Up to 12,000 Lumens per Mtr
- Up to 25 Watts per 200mm module
- IP ratings available: IP20, IP65 & IP66



## 3D LED Flex 100

- Up to 11,000 Lumens per Mtr
- Up to 11 Watts per 100mm module
- IP ratings available: IP20, IP65 & IP66



## 3D LED Flex 40

- Up to 5,000 Lumens per Mtr
- Up to 5 Watts per 100mm module
- IP ratings available: IP20, IP44, IP65, IP66 & IP68



## 3D LED Flex 25

- Up to 4,000 Lumens per Mtr
- Up to 4 Watts per 100mm module
- IP ratings available: IP20, IP65, IP66 & IP68



# 3D LED Flex Range

Modular + Linear + 3D Flexible

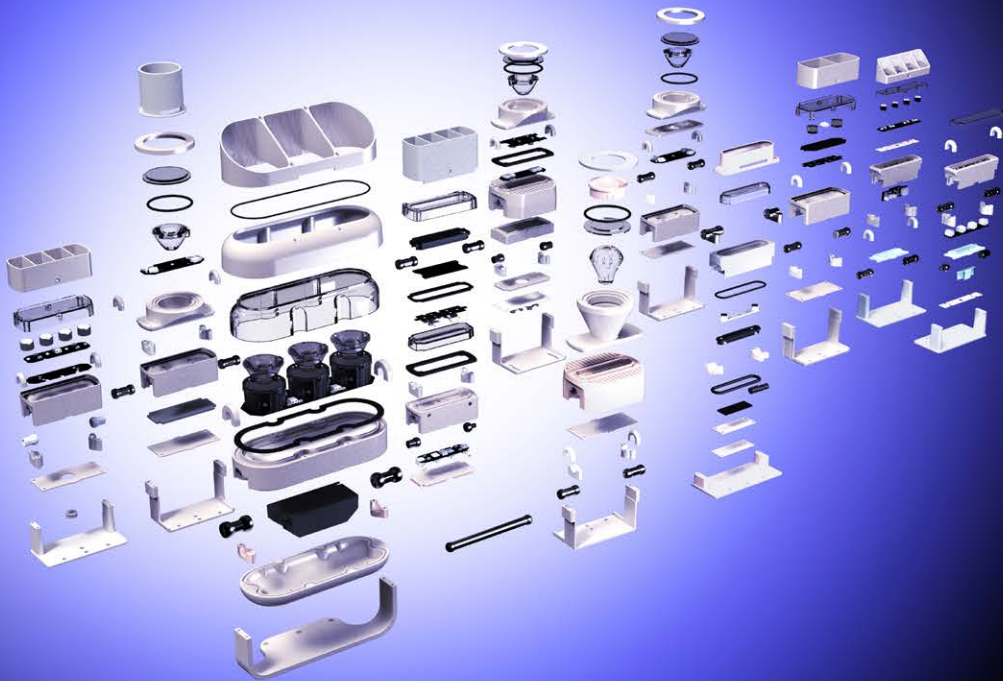

The 3D LED Flex range is modular and the various components can be assembled together in different combinations to meet project requirements. Every element from the light engine and optics, to the anti-glare accessories and bracketry can be customised. We are continuously developing new components for the system as the scope of our projects expands.



Twin module



Two-level bracket



Single modules on adjustable-angle brackets



Wider spaced modules with extended ball-joints

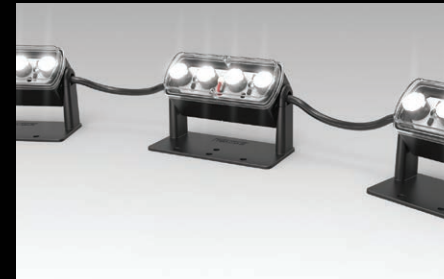

Single modules with flexible cable link



Customisable anti-glare accessories



Custom finishes for metalwork and louvres



Custom light engines and optics for each project

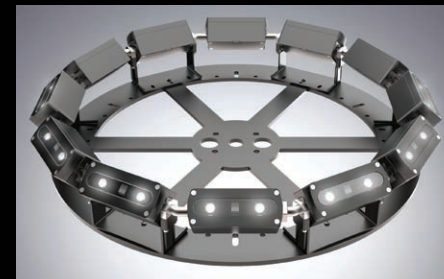

Custom bracket solutions



Strip lengths up to 2.5 Mtrs

# Circular economy approach

## Repair + Replace + Reuse

Radiant is working to reduce the long-term environmental impact of its systems with a variety of approaches.

Radiant's award winning lighting systems have always been designed for efficient operation, longevity, ease of on-site repair, easy disassembly, refurbishment, rebuilding, and for eventual recycling of materials.

Using traditional construction methods allows Radiant systems to be easily disassembled and then reassembled into new products. Up to 95% of our cast, extruded, and moulded components can be reused indefinitely. We design our systems for a working life of up to 30 years including replacement of light engines and integral drivers.

Easy on-site replacement of light engines is a key element of the design of all new Radiant systems.

Working with partners in an increasing number of markets for local component production and system assembly will reduce the carbon generated by moving finished products around the world.

All Radiant systems come with a 5-year guarantee and we will provide a refurbishment and repair service thereafter to ensure that they operate efficiently for the longest possible time.

A TM 66 analysis of each Radiant system can be prepared for your projects.

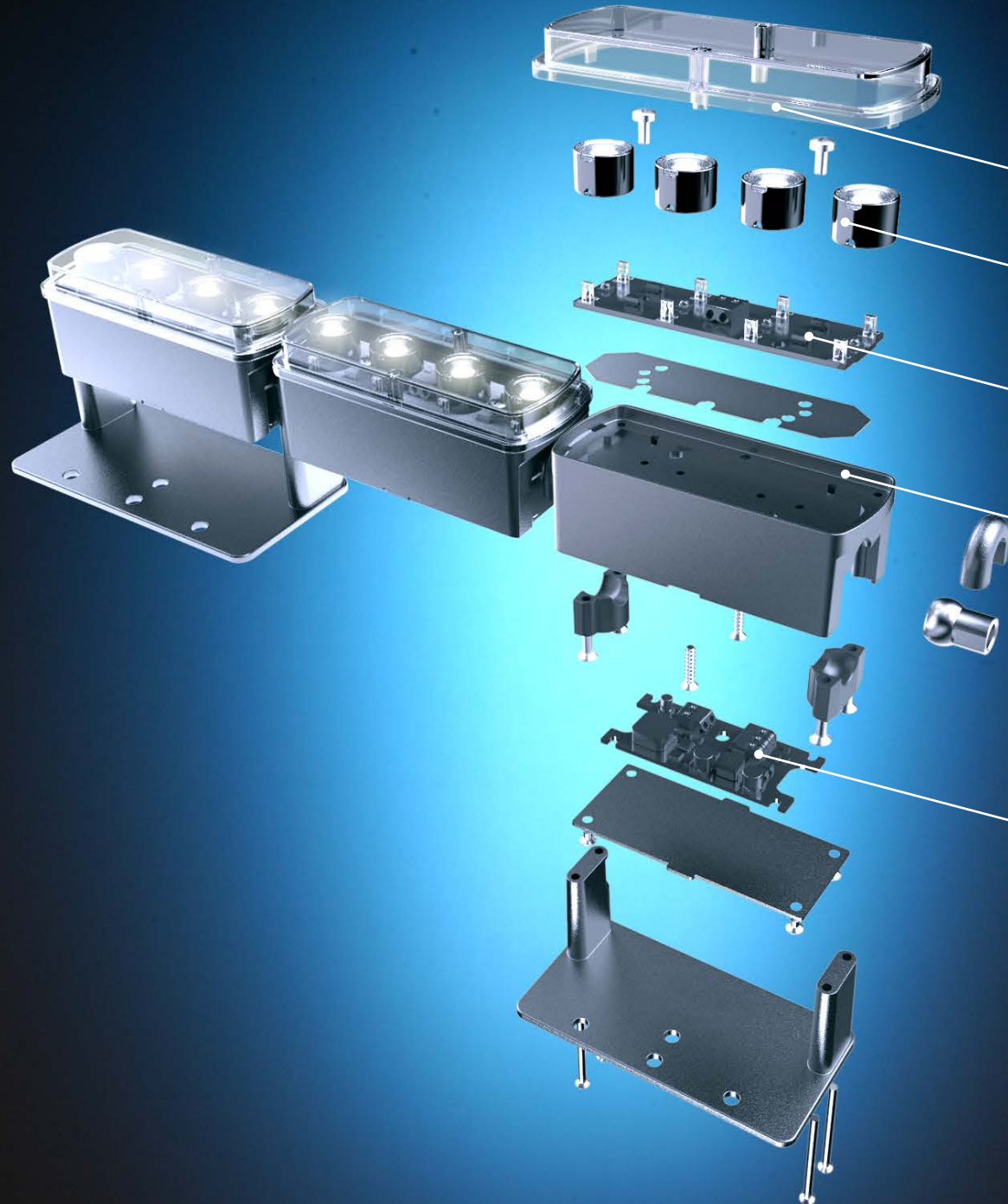

Radiant systems are designed to reduce embodied carbon during production, allow on site repair, reuse of components and easy recycling at the end of life.

Glass, acrylic & polycarbonate windows options are available for most Radiant systems.

Lenses can be mounted onto light engines using spring clips or snap fits to allow easier recycling and reuse.

Aluminium core PCBs are used in almost all Radiant products to allow them to be recycled at the end of the light engine's life.

Pressure die cast aluminium heatsinks waste less material during production than machined components.

Radiant die castings are currently produced with up to 75% recycled aluminium material. We aim to use only 100% recycled cast aluminium within 3 years.

LED light engines and LV drivers can, in most cases, be replaced on site, at their end of life, with no soldering required.

Opaque plastic components can be 3D printed locally. Injection moulded components will use recycled material as soon as practicable.

Radiant systems are modular, durable, and can be refurbished and rebuilt many times.

# 3D LED Flex 200 IP66

## Modular, 3D flexible LED exterior linear lighting system

The 3D LED Flex 200 IP66 system has been developed for use in a wide variety of large-scale exterior architectural lighting projects requiring wall grazing and wall wash lighting where the building surfaces are non-linear with curved profiles and facades. The patented articulated ball-joint system joining the heat-sink modules allows the system to follow complex curved building profiles.

The latest and largest addition to the range, the 3D LED Flex 200 can be run at up to 125 Watts per Mtr, providing up to 12,000 Lumens per Mtr. Each 200mm long module comprises of 3 x arrays of 4 x RGBW Luxeon-Z LEDs with highly efficient Gaggione colour-blending lenses.

Integral AC to DC constant current drivers allow long lengths to be powered from a single power feed. Dimming interfaces include DALI, DMX, and 1-10V.

The system has minimal visible fixings and anti-glare snoods provide excellent glare control.



Up to 12,000 Lumens per mtr



3D LED Flex 200 IP66

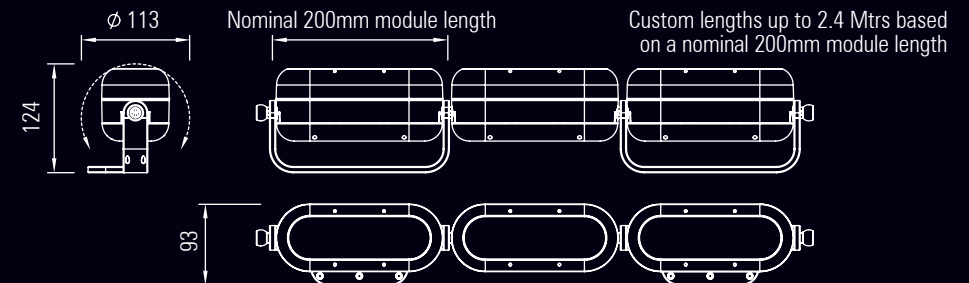

## 3D LED Flex 100 IP20

### Modular, 3D flexible LED interior linear lighting system

The Radiant 3D LED Flex 100 system was the first type in the range and was originally developed for the Heydar Aliyev Centre project to provide all the ambient lighting in the auditorium. The system has been further developed for use in a wide variety of other architectural lighting projects requiring cove lighting and wall wash lighting where the building surfaces are non-linear with curved profiles and facades.

The patented articulated joint system joining the heat sinks allows the system to follow curved building surfaces while maintaining a 25mm spacing between LEDs, thus ensuring continuous lit effects without shadows or dark areas.

Each LED heat sink module can operate up to 11 Watts of LEDs giving a light output of up to 11,000 lumens per mtr.

Integrated LV DC to DC constant current drivers allow long runs to be powered from a single remote power supply.



Custom lengths up to 2.5 Mtrs based on a nominal 100 mm module length

Nominal 100mm module length

Up to 11,000 Lumens per mtr



Heydar Aliyev Centre  
Architect Zaha Hadid Associates  
Lighting design by MBLD





Burberry flagship store, Regent Street, London. Lighting design by Russell Lipscombe



28 x 0.3 Watt medium power LEDs with white reflector per module



4 x high power LEDs with lenses per module



1 x 10 Watt RGBW LED array with asymmetric reflector per module



1 x 10 Watt RGBW LED array with colour-blending lens per module



The McEwan Hall, University of Edinburgh. Lighting design by Buro Happold

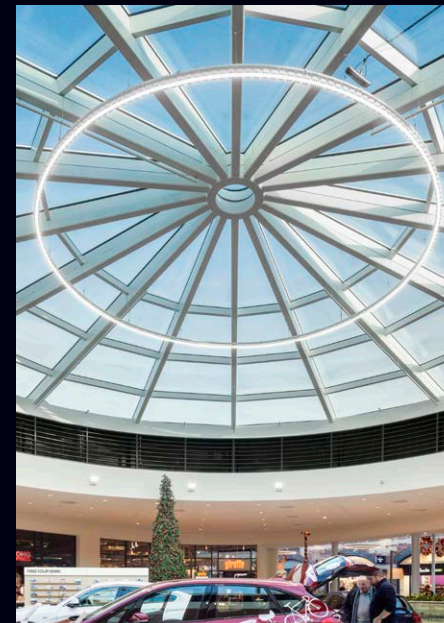

Designer outlet, UK. Lighting design by Aecom



Mall of Oman. Lighting design by Aecom

# 3D LED Flex 100 IP66

## Modular, 3D flexible LED exterior linear lighting system

The Radiant 3D LED Flex 100 IP66 system has been developed for use in larger scale exterior lighting applications where the building surfaces are non-linear with curved profiles including columns, domes and curved facades.

The articulated joint system allows the LED heat sinks to follow three dimensionally curved surfaces while maintaining a 25 mm spacing between LEDs, thus ensuring continuous lit effects without shadows or dark areas.

A digital thermal control system ensures that the LEDs work at an optimal temperature even in high ambients.



Up to 10,000 Lumens per mtr

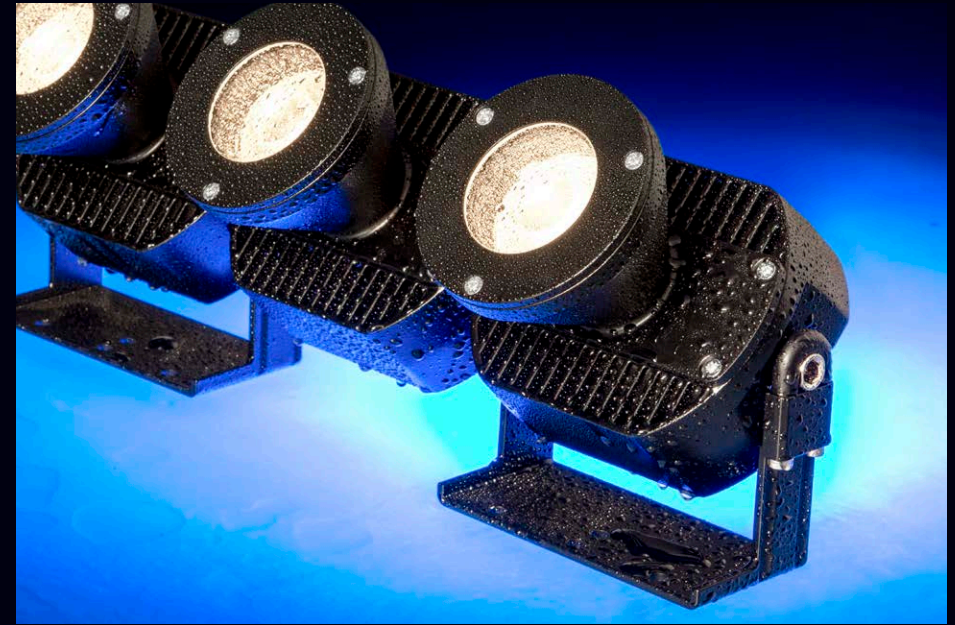

Ultra narrow beam 4 degree lenses



Intu Lakeside Shopping Centre. Lighting design by Hoare Lea

## 3D LED Flex 40 IP20

Modular, IP20 3D flexible LED interior linear lighting system

The Radiant 3D LED Flex 40 IP20 system incorporates the widest range of versions and options and has been specified and installed on the greatest number of projects to date.

The system can be run at up to 50 Watts per mtr and provides over 5,000 lumens per mtr depending on LED colour temperature and type.

The system includes interior IP20, exterior IP66 and underwater IP68 versions.



**GERMAN  
DESIGN  
AWARD  
WINNER  
2019**

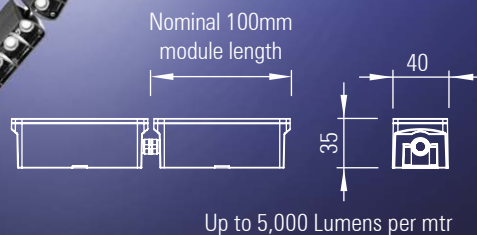

WestQuay Watermark, UK  
Lighting design by George Sexton Associates





Dior store, Riyadh. Lighting design by Metis lighting



3D LED Flex 40 IP20. High-power LEDs with optics



Chutney Mary, London. Lighting design by BPA

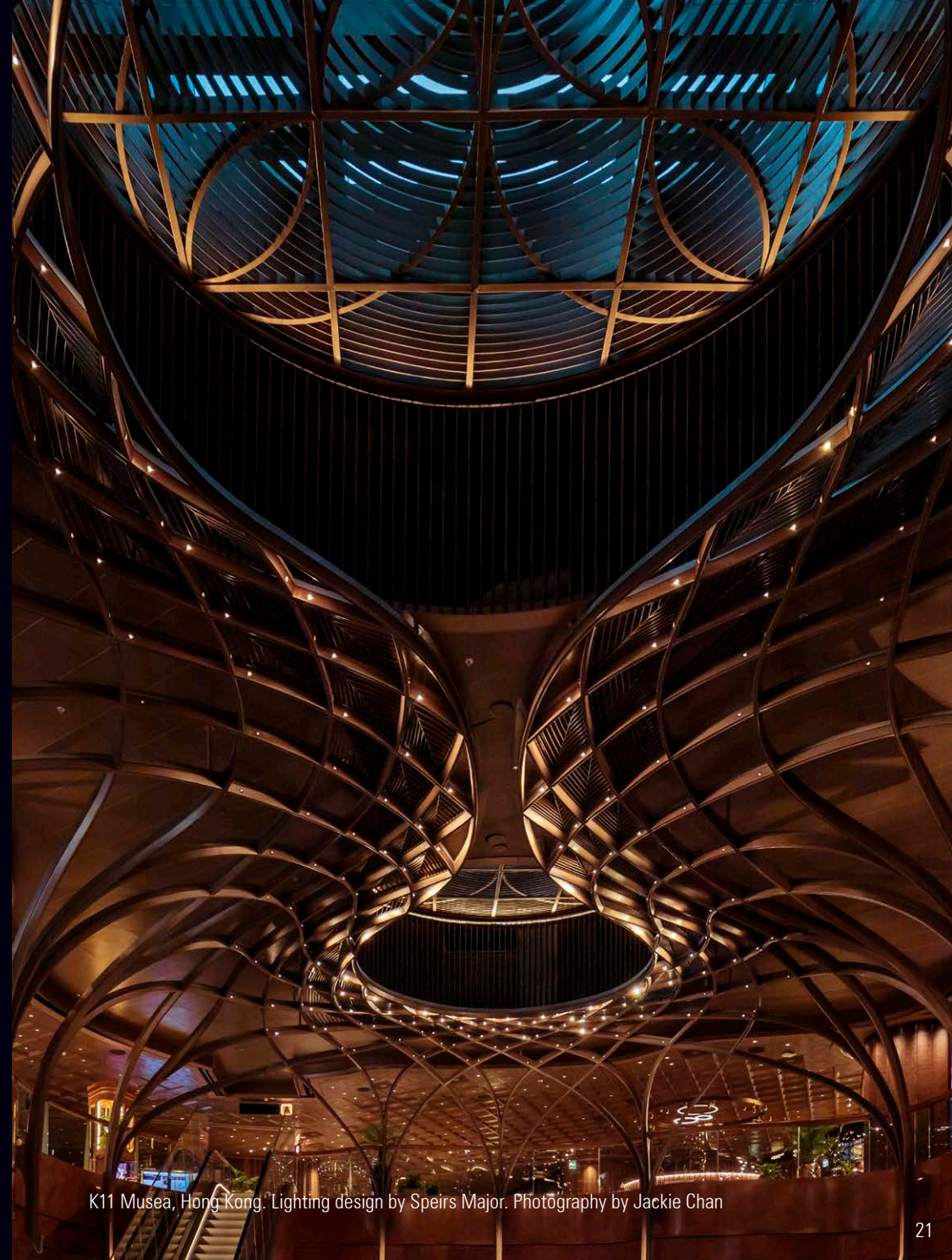

K11 Musea, Hong Kong. Lighting design by Speirs Major. Photography by Jackie Chan



Virgin Voyages' Scarlet Lady cruise ship

Lighting design by Cinimod



Hammersmith Apollo auditorium. Lighting design by Jim Morse Lighting



Hammersmith Apollo foyer. Lighting design by Jim Morse Lighting



3D LED Flex 40 IP20 RGBW - colour-mixing optics

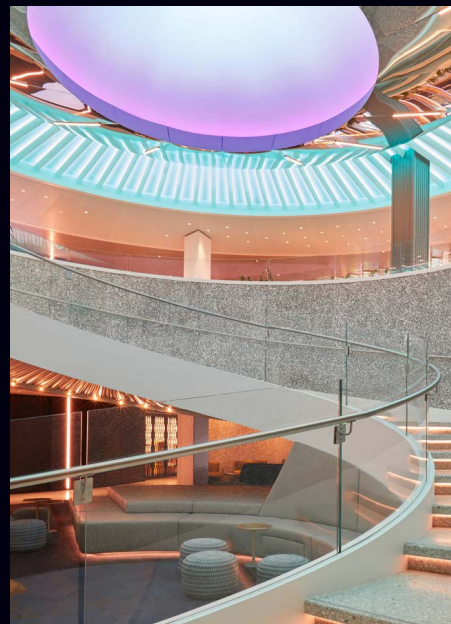

Project photography by Virgin Voyages



3D LED Flex 40 IP20 RGBW - 32mm colour-mix optics



3D LED Flex 40 IP20 RGBW - white reflector

## 3D LED Flex 40 IP66

### Modular, IP66 3D flexible LED exterior linear lighting system

One of the early developments of the 3D LED Flex 40 system was an exterior IP66 rated version so that the same system can be used to light both interior and exterior projects. The system has also been used to light pools and hammams where high humidity would cause problems for an IP20 rated system.

The most popular elliptical optic version has been used to graze domes, curved roof surfaces and facades. The 100mm module allows the system to be tailored to fit any building size and shape.

The system can be run at up to 50 Watts per mtr providing over 5,000 lumens per mtr. With many options for LED light engines, optics, mounting brackets and anti-glare accessories the system can be configured for each project.

A thermal control system is used in high ambient conditions to keep the LEDs working at an optimum temperature.



Up to 5,000 Lumens per mtr



University of Edinburgh Old College dome, UK  
Lighting design by Nich Smith Lighting Design



The Bvlgari Spa, Dubai. Lighting design by Delta lighting solutions, Dubai  
Winner of the Light Middle East Award for Hotel Lighting Project of the Year



Deniz Mall, Baku, Azerbaijan  
Lighting design by MBLD



3D LED Flex 40 IP66 system. Each module comprises 4 x Luxeon Z red LEDs with a Gaggione ultra-narrow beam lens, and custom height anti-glare snoot. Each module is individually addressable via DMX

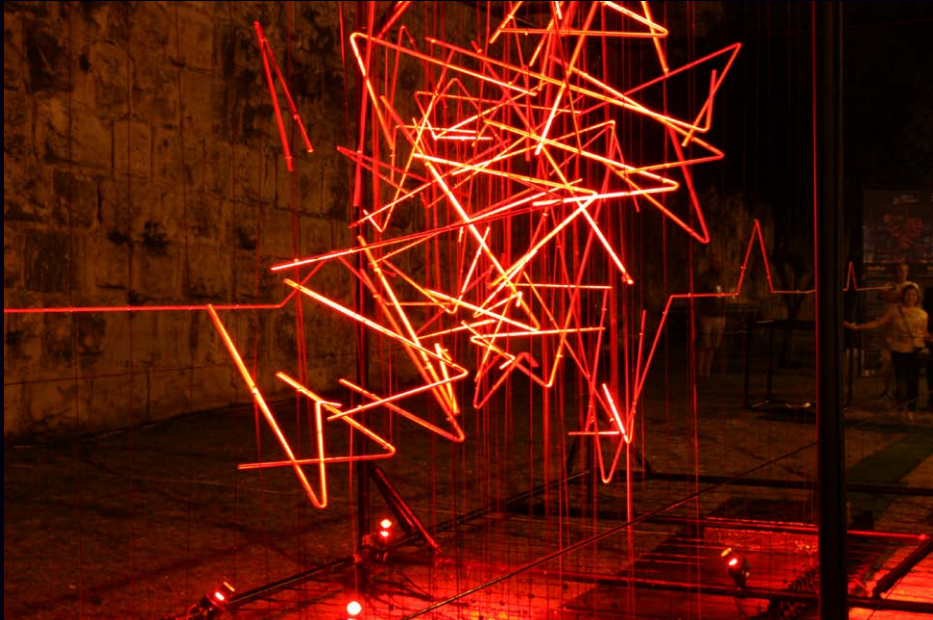

Heart Beat installation. Installation and lighting design by GNI Projects

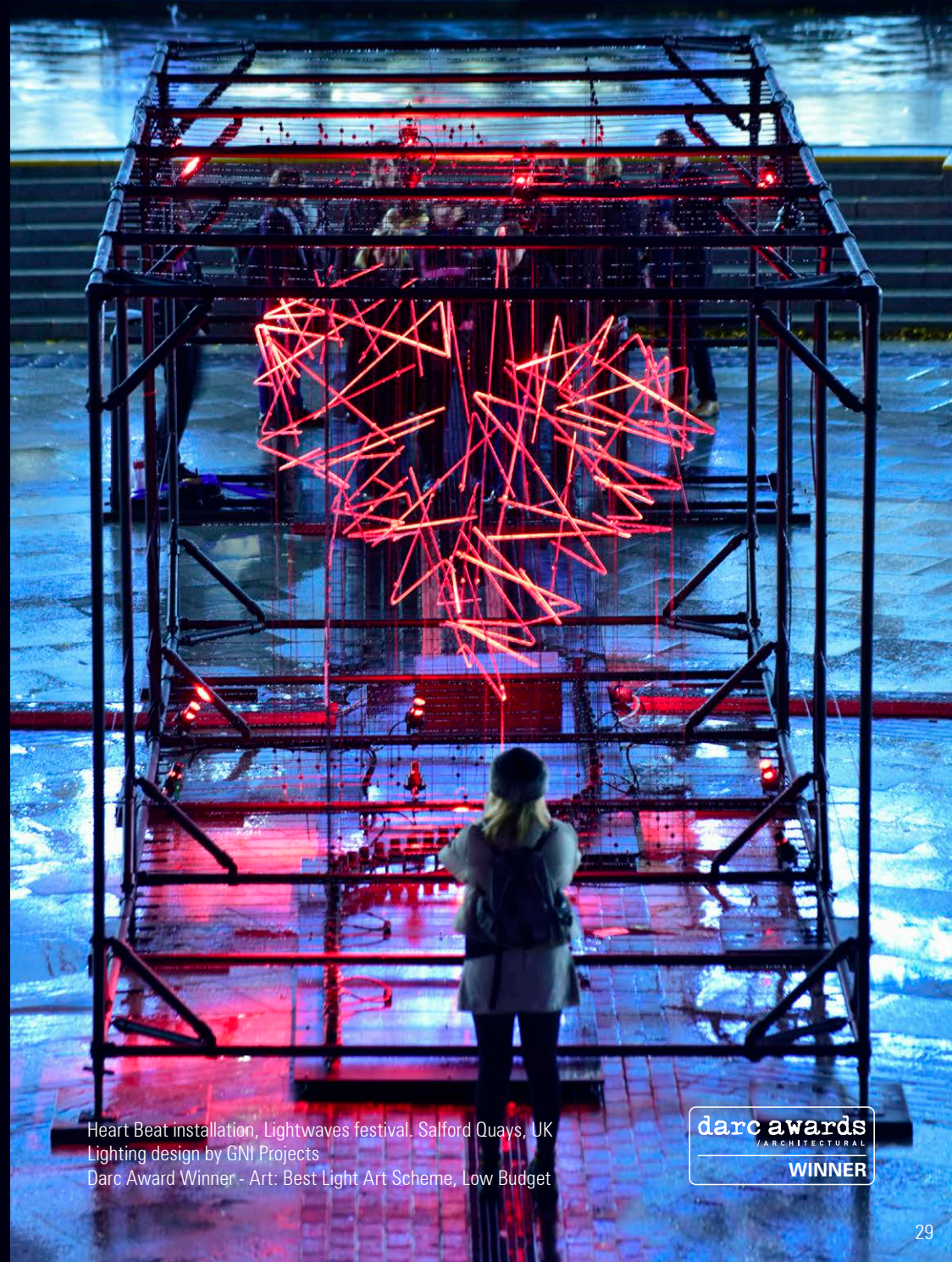

Heart Beat installation, Lightwaves festival. Salford Quays, UK  
 Lighting design by GNI Projects  
 Darc Award Winner - Art: Best Light Art Scheme, Low Budget







3D LED Flex 40 System IP66 RGBW - 200mm module pitch  
Each module is individually addressable via DMX



South Devon College, UK. Lighting design by Michael Grubb Studio. Photograph by Tom Davey



8 or 12 x 0.3 Watt medium power LEDs with white reflector per module



1 x RGBW array with reflector per module



4 x high power LEDs with lenses per module



1 x RGBW or Tunable white array with 32mm Ø colour-blending lens per module



1 x high power LED with ultra-narrow beam spot or ultra-narrow elliptical beam lens per module



1 x RGBW or Tunable white array with colour-blending lens per module

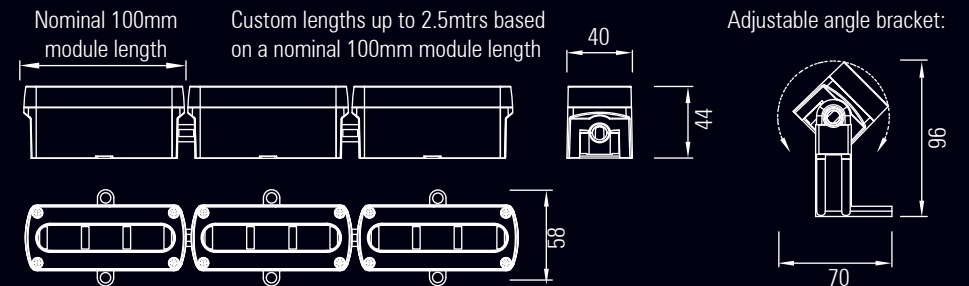

# 3D LED Flex 40 IP68

## Modular, IP68 3D flexible LED underwater linear lighting system

The Radiant 3D LED Flex 40 IP68 system is designed for use in underwater applications where curved lines of light are required. The system components are cast in 316 L stainless steel and are suitable for use in saline and chlorine environments including pools, fountains and marine projects. The pressed glass windows are bonded to the module bodies and all LED and internal driver boards are potted in silicone resin to ensure long working life at up to 2 mtrs depth.

The patented articulated joint system joining the LED modules allows the system to bend and twist in three dimensions to follow curved building surfaces while maintaining a constant spacing between LEDs. Output up to 4,000 lumens per mtr.



Nominal 106mm module length  
Custom lengths up to 2.5mtrs based on a nominal 106mm module length

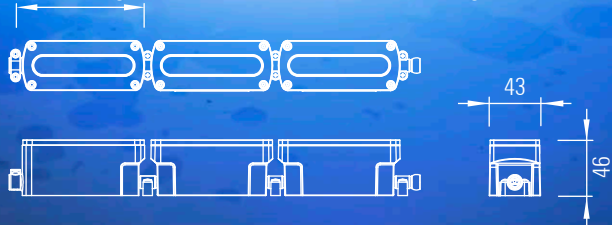

Up to 4,000 Lumens per mtr



3D LED Flex 40 IP68 RGBW or Tunable white with mini 32 mm diameter colour-blending Gaggione lenses



# 3D LED Flex 25 IP20

## Modular, 3D flexible LED interior linear lighting system

The Radiant 3D LED Flex 25 system incorporates many of the design features of the 100 and 40 systems but with a smaller width of only 25 mm.

The system is ideal for use in smaller architectural, retail and hospitality lighting applications.

This is the most cost effective version of the 3D LED Flex range and has a light output of up to 4,000 lumens per mtr.

Like the larger sizes, the 25 system is available with a wide range of light engines, optics, dimming interfaces, anti-glare accessories and mounting bracketry to suit each project.



Nominal 100mm module length



Up to 4,000 Lumens per mtr



8 or 12 medium power LEDs per module



4 x high power LEDs with lenses per module



Anti-glare snout accessories



200mm double-spacing between modules



Sydney Lyric Theatre, Australia. Lighting design by Schuler Shook

# 3D LED Flex 25 IP66

## Modular IP66 3D flexible LED exterior linear lighting system

The Radiant 3D LED Flex 25 IP66 system is designed to be used in a wide variety of exterior lighting applications where a lower light output and smaller width is needed than the larger types also available in the range.

The system is ideal for use in smaller architectural and facade lighting applications. The system is available in a wide variety of LED, lens and reflector options and can be supplied with pressed glass windows for use in high sunlight situations or where sand abrasion is an issue.

A thermal control system is used in high ambient conditions to keep the LEDs working at an optimum temperature.



Up to 4,000 Lumens per mtr



Mid-power LED version with adjustable angle brackets



High power LEDs with lenses version with fixed angle mounting brackets



200mm double-spacing between modules



Anti-glare snoot accessories

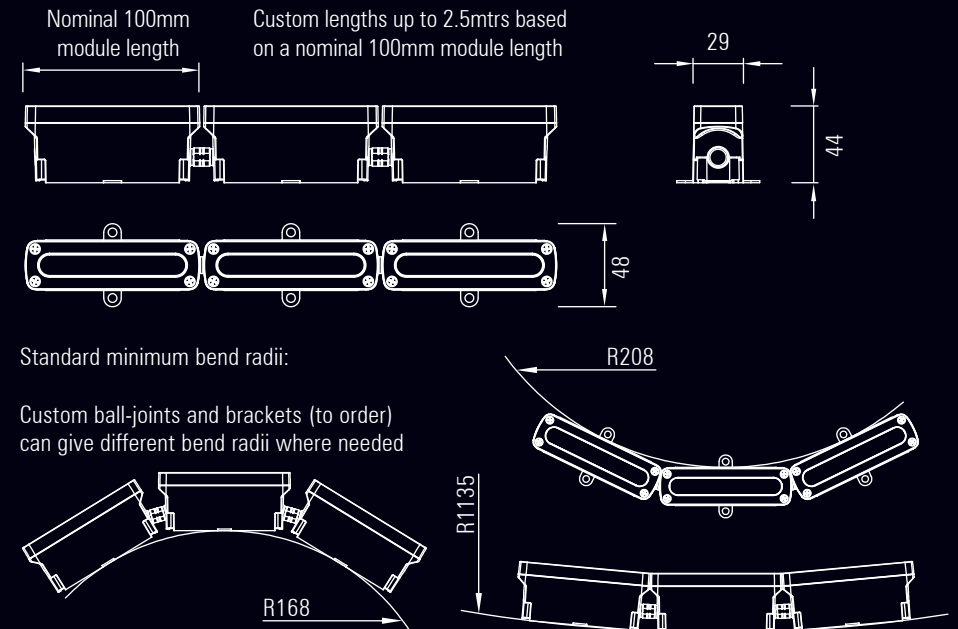

# 3D LED Flex 25 IP68

## Modular IP68 3D flexible LED linear lighting system

The Radiant 3D LED Flex 25 IP68 system is designed for underwater applications where the building surfaces are non-linear with curved profiles. The articulated joint system joining the LED heat sinks allows the system to follow curved building surfaces while maintaining a constant spacing between LEDs, thus ensuring continuous lit effects without shadows or dark areas.

The system is submersible up to 2 mtrs. The system components are cast in 316 L stainless steel and are suitable for use in saline and chlorine environments including pools, fountains and marine projects. Each module incorporates two Cree XPE LEDs with or without lenses.

The system can be run at 25 Watts per mtr and provides up to 2,500 lumens per mtr.

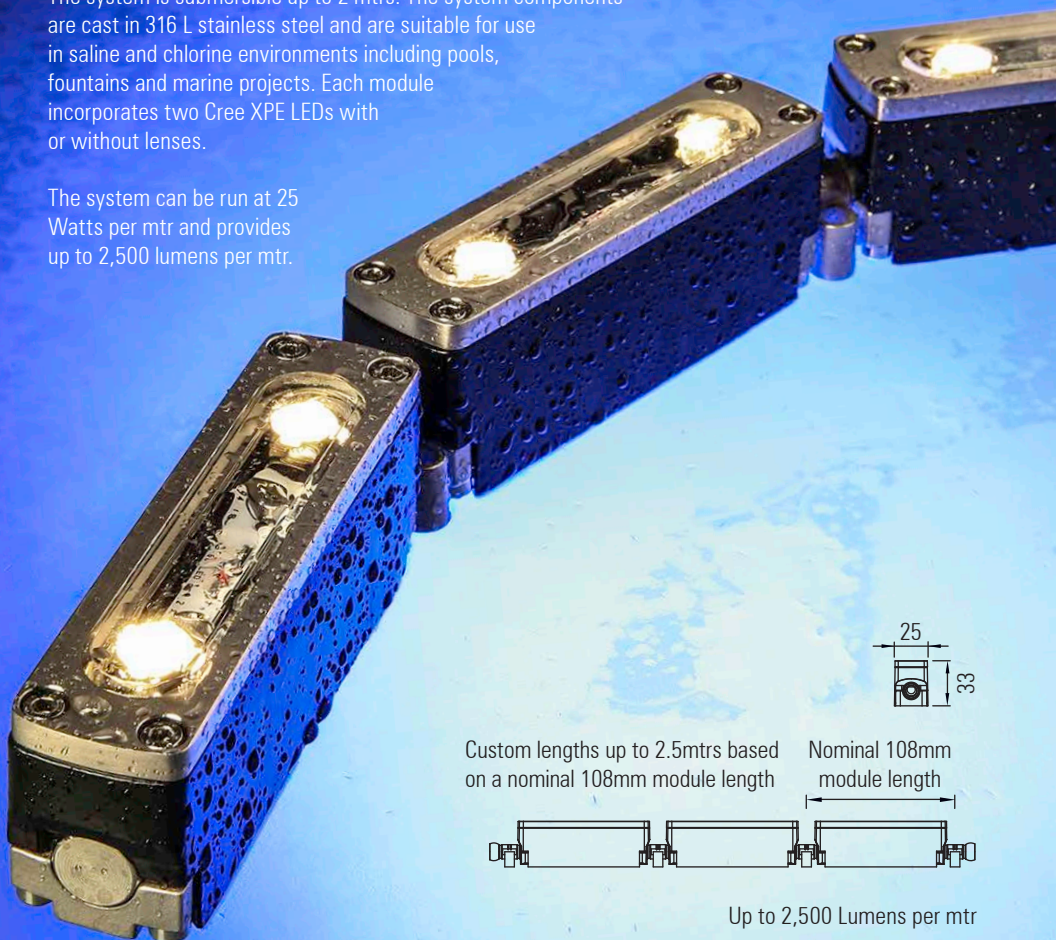

Custom lengths up to 2.5mtrs based on a nominal 108mm module length

Nominal 108mm module length



Up to 2,500 Lumens per mtr



3D LED Flex 25 IP68 with adjustable angle brackets and anti-glare snoot accessory



Chanel Spa at the Ritz Hotel, Paris. Lighting design by Schwinghammer Lighting Design, New York

# Centura

## Modular, interior flexible linear LED pendant system

Centura is a flexible LED interior linear lighting system, designed to make complex designs simple. An innovative design offers the flexibility to follow curved surfaces, encircle columns and domes, and to make irregular shaped pendants, all whilst offering excellent lighting control and uniformity.

The system is available in uplight and downlight and aimable side accent-light solutions, surface mounted or suspended, and with a light output of up to 6,500 lumens per mtr, making it ideal for a wide range of application areas including architectural, hospitality, leisure and retail.

The body and anti-glare louvres are available in all RAL colours, including gold for warmth, black for a dark light effect and red for dramatic impact.

In addition to the original Centura 40 System, with a module length of 100mm and width of 40mm, the Centura 40 150 System has a module length of 150mm, whilst maintaining the 40mm module width.

The Centura 60 System, with a module length of 100mm and width of 60mm, incorporates high-efficiency Gaggione colour-blending lenses and is designed for applications where highly-controlled RGBW or Tunable-white lighting effects are required.

Up to 6,500 Lumens per mtr

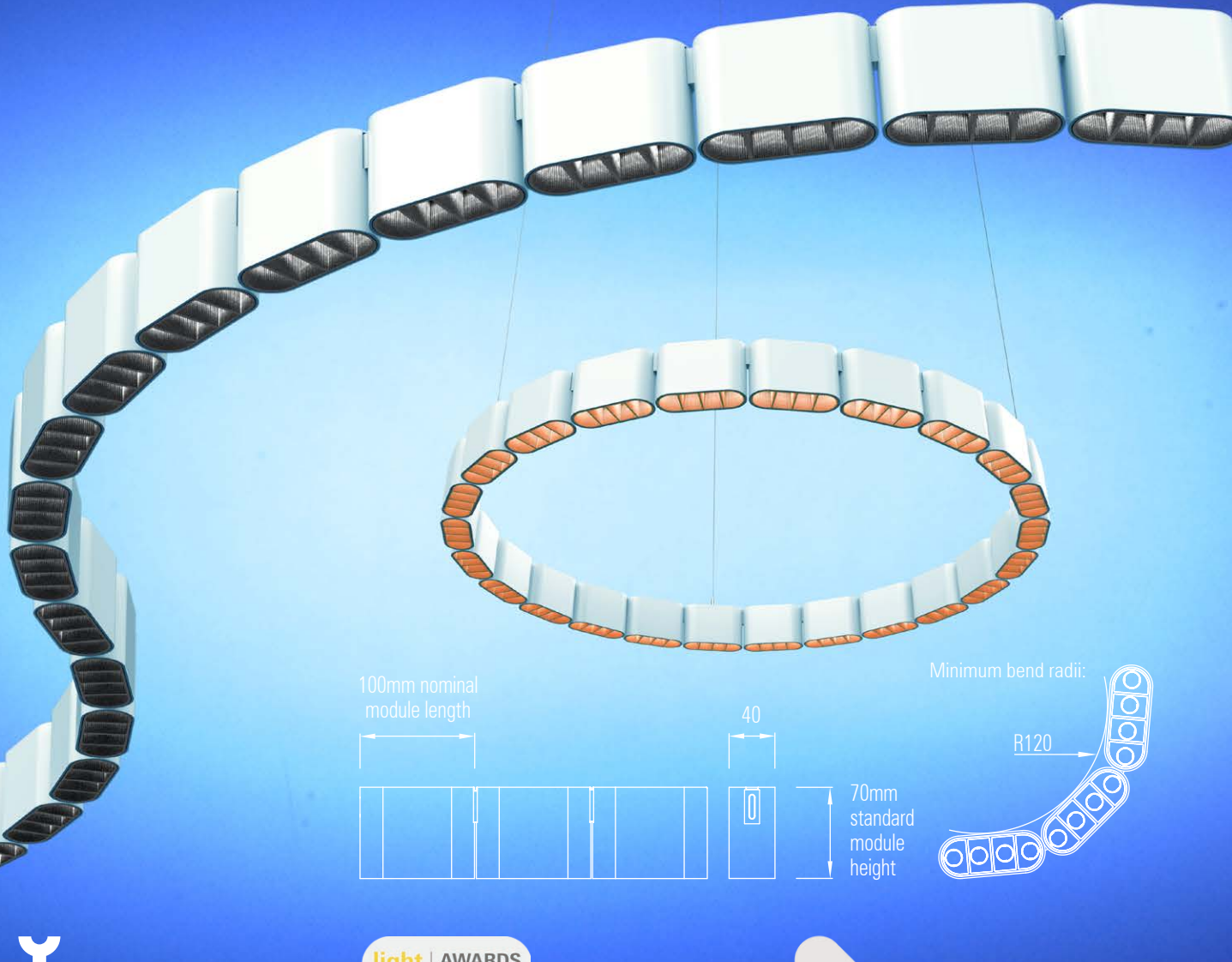

100mm nominal module length

40

Minimum bend radii:

R120

70mm standard module height



2021  
WINNER  
LIGHTING  
DESIGN  
AWARDS



GERMAN  
DESIGN  
AWARD  
WINNER  
2020



# Centura

Modular, interior flexible linear LED pendant system

Downlight, uplight and aimable projector side-light options.  
Flexible articulated modular fixtures  
or custom fixed-shape fixtures.

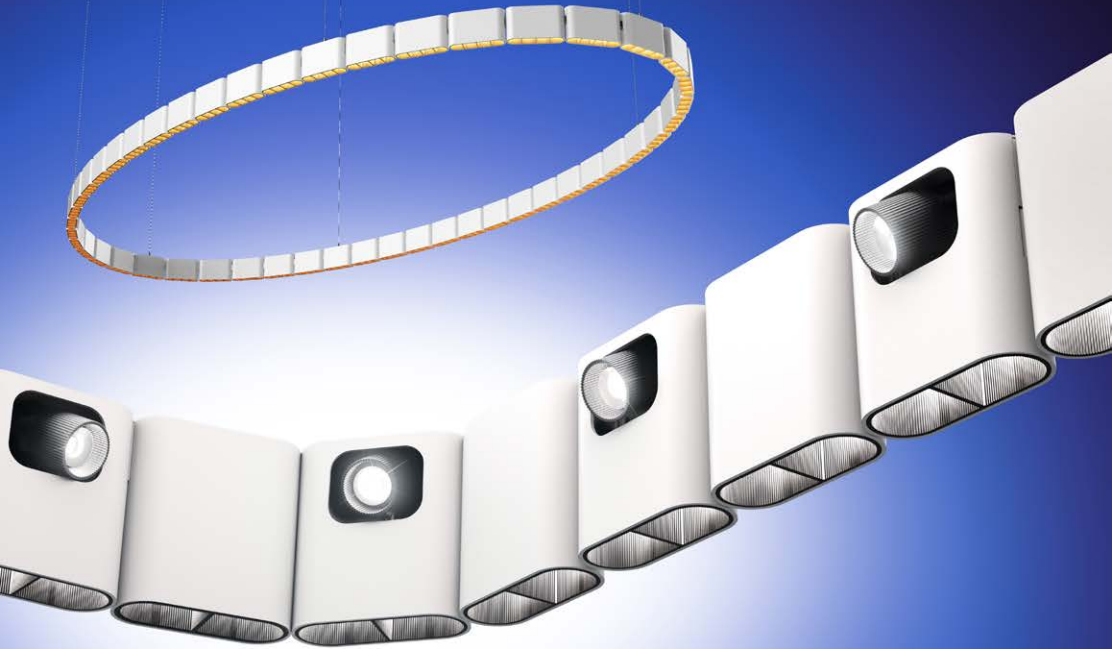

Centura 60 RGBW - with colour-mixing optics



Centura 40 150 IP20 - with opal diffuser



Encompass Control Room, London

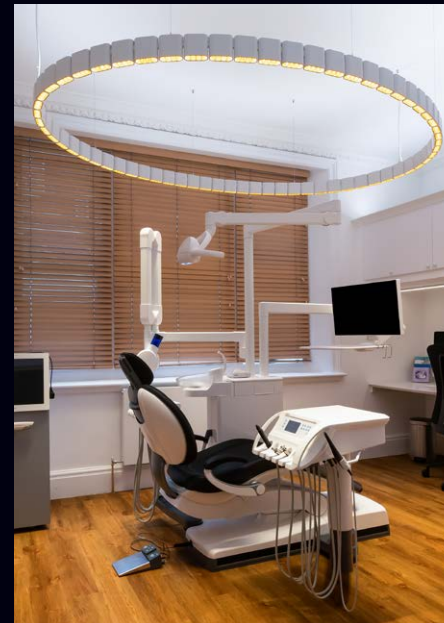

Wimpole Street Dental Clinic, London



Lighting design by Syntax Lighting

# Centura

Modular, interior, flexible, linear LED pendant system



Radiant's Centura System IP20 was specified by London based lighting designers, 18 Degrees, as part of the lighting scheme for the new headquarters of the prestigious law firm, Freshfields. The linear modular Centura system, with high-power LEDs and elliptical beam lenses, provides a highly-controlled light grazing effect in several locations throughout the building. The system was produced as a series of custom curved and straight fixed-shape lengths. The surface-mounted system is recessed within the ceiling details. The anti-glare louvres ensure excellent visual comfort.



Freshfields Bruckhaus Deringer, London



Freshfields Bruckhaus Deringer, London. Lighting design by 18 Degrees



Private residence, London. Lighting design by Syntax lighting



# Serpentine

## Flexible IP65 LED Linear lighting system

The Radiant Serpentine exterior LED linear system was the first system of its type to be hand bendable on site, and to offer adjustment in both the axial and vertical planes.

The Serpentine system is designed to be used in a wide variety of exterior building facade lighting, wall-grazing, landscape and other exterior architectural lighting applications.

The individual LED lighting modules can rotate around the axis of the system and between the joints allowing the system to be curved to follow building profiles and architectural details and for the light output to be aimed to give optimum grazing or feature lighting.

Up to 65 Watts per mtr.  
Up to 6,000 lumens per mtr depending on LED colour temperature.

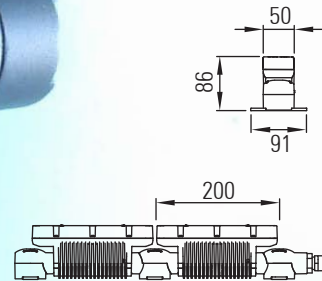
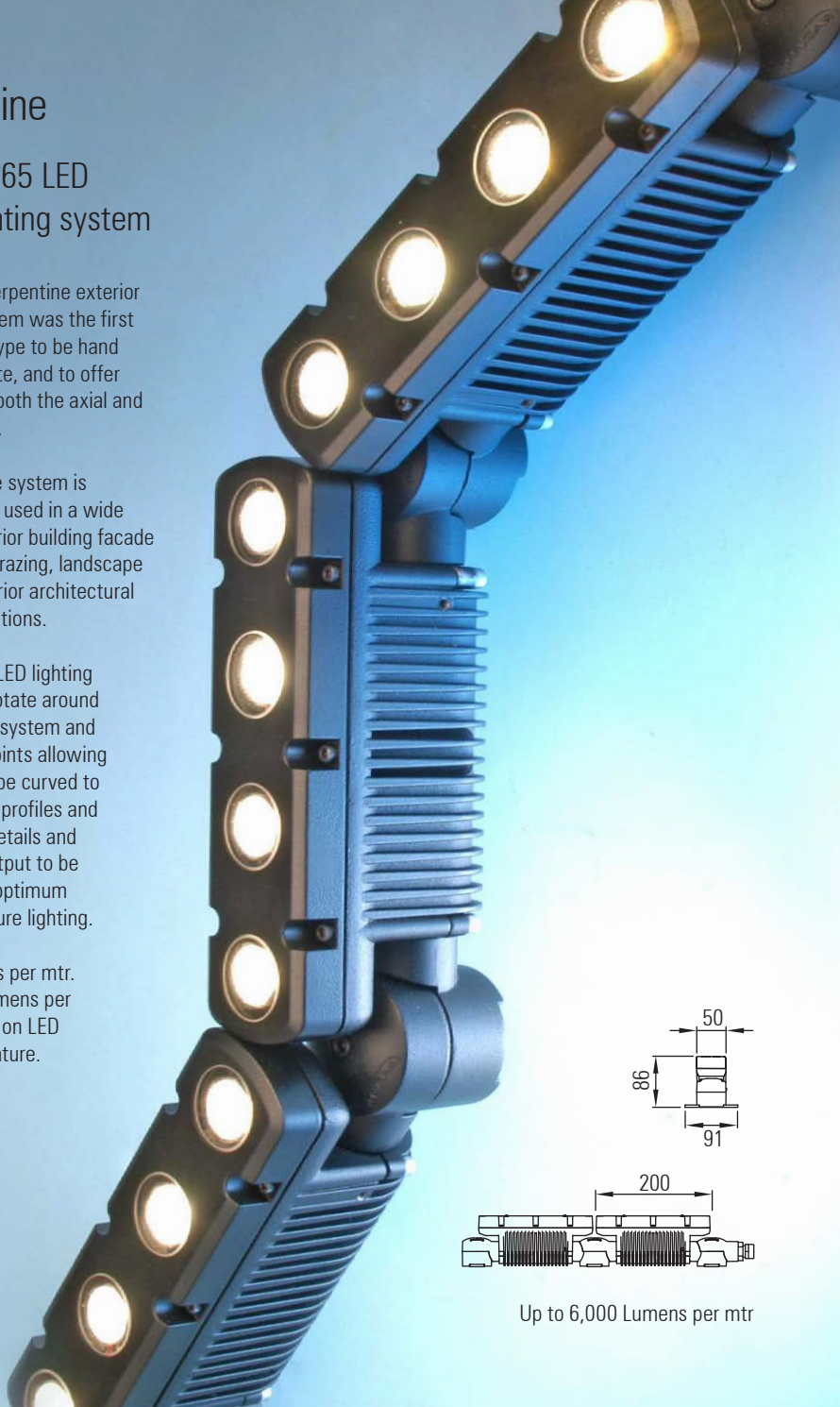

Up to 6,000 Lumens per mtr



Goodman's Fields, London. Lighting design by EQ2 Light. Photo by Simon Winson - Berkeley Group



TFL project. Architect Burns and Nice. RIBA award winner

# F Grazer

## LED linear lighting system

The F Grazer system has been developed for use in hospitality lighting projects, to produce surface grazing effects where a minimal and cost-effective solution is required. In its simplest form the 330 mm light engine modules, complete with narrow elliptical lenses, are combined with the extruded body heat sink to provide an efficient concealed grazer luminaire. Direct fixing through the heat sink extrusion.

Glare control louvres, optical film diffusers, clear covers and end caps can be added to create a fully featured linear lighting system. A self-locking adjustable angle version is also available.

On board constant current linear drivers ensure the tightly binned LEDs are run at the optimum drive current.

Up to 10 mtrs of the system can be run from a single remote LV power supply. Dimming is via a separate pwm channel with an interface to all standard dimming systems.

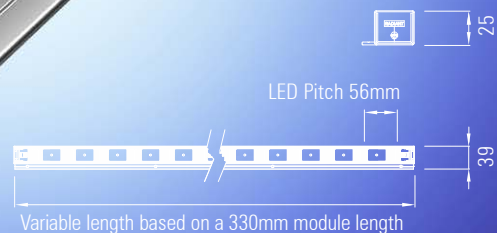

Up to 2,000 Lumens per mtr



Amara Hotel, Cyprus  
Lighting design by Damien McKay, Light 360

# Shard undercabinet

## LED Linear lighting system

The Shard linear lighting system was developed with George Sexton Associates for use in the apartments of the iconic Shard building in London.

The system incorporates medium power LED light engines, with on board linear drivers, in a wide variety of colour temperatures with CRI up to 95. Up to 1,500 lumens per mtr. Dot free opal or clear window versions are available.

The system can be supplied in any length up to 2.5 mtrs. Smallest cutting module based on 100mm LED pitch. Longer continuous runs plug together on site.

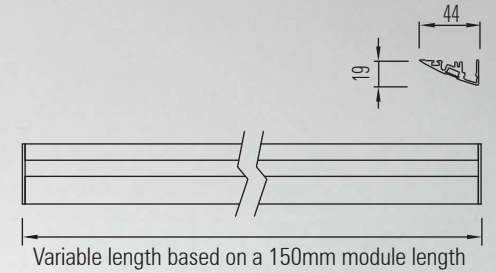

Up to 1,500 Lumens per mtr

# Flaplight

## LED Linear display lighting system

The Radiant LED Flaplight system incorporates lockable, hinged barn-door flaps to control glare and cut-off.

The system has been developed for a wide variety of linear display lighting applications including museums, galleries and retail.

The lighting head can be fitted with a variety of lenses to control the beam angle.

The flaps and body can be locked at the correct aiming angle.

Integral LV constant current drivers are dimmable with all systems.

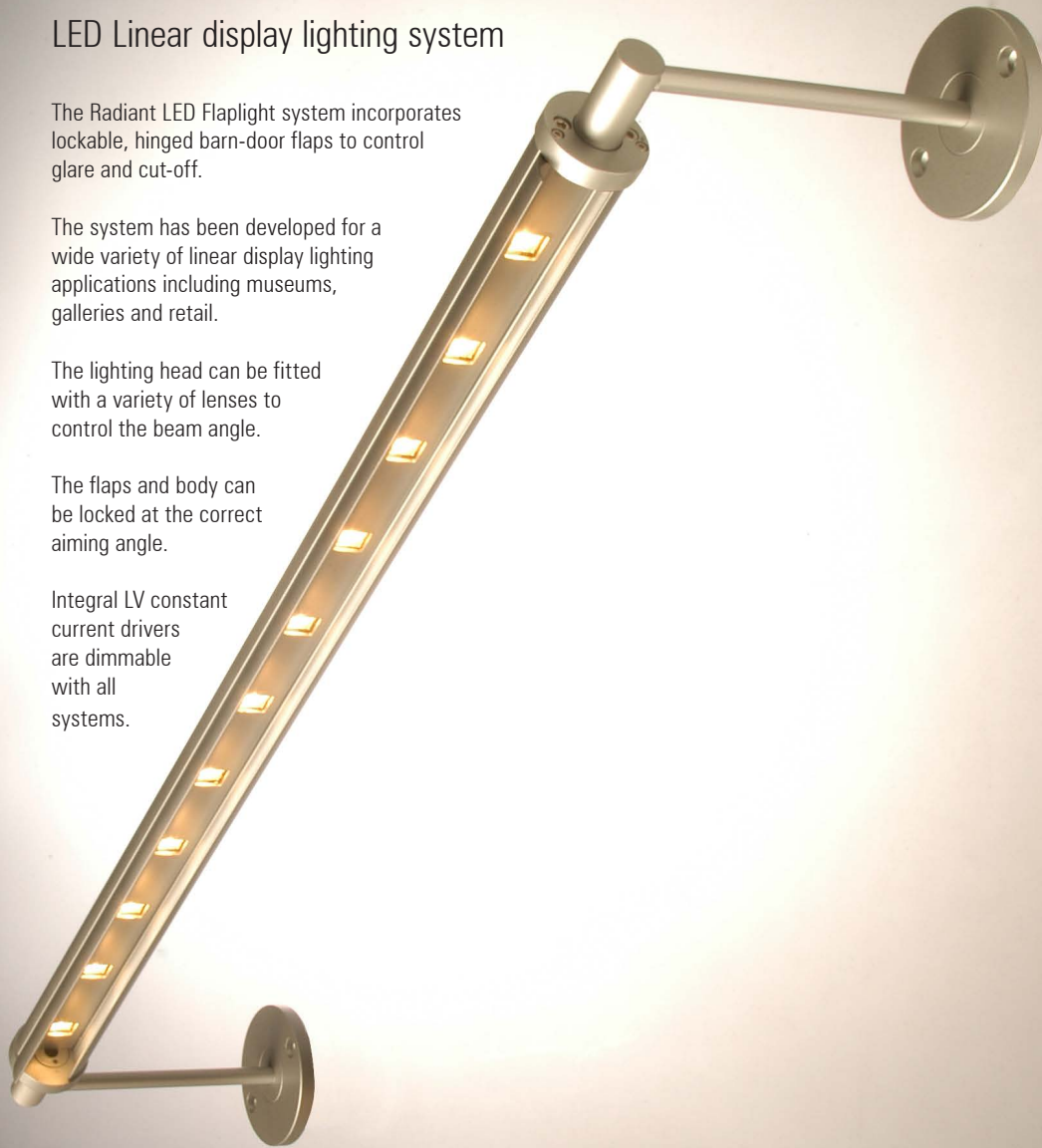

Up to 3,000 Lumens per mtr

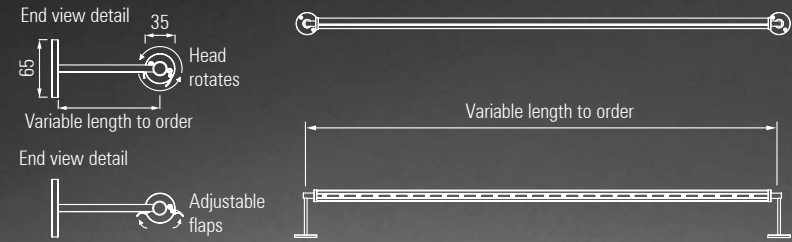

Suspended pendant version (above)  
Each of the flaps can be locked using an Allen key



Flaps can be closed to control glare and cut-off



# Flaplight Micro and Flaplight Nano

## LED Linear display lighting system

The Radiant Micro and Nano Flaplight systems extend the range with smaller sizes suitable for use in residential projects and within display cases.

The Micro incorporates the same lockable, hinged barn-doors as the standard size Flaplight.

The Nano has fixed flaps to give excellent glare control and visual comfort in the smallest overall size.

The smaller systems incorporate a linear lens for excellent beam control or for a softer diffuse lit effect.

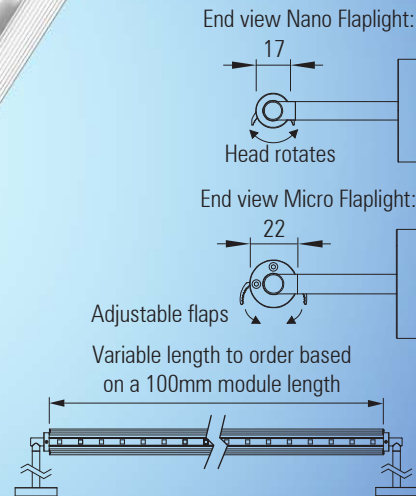

Nano: Up to 1,500 Lumens per mtr  
Micro: Up to 2,500 Lumens per mtr

# Euclid 12

## LED linear lighting system

The Euclid 12 system was developed with George Sexton Associates as a custom design for a major residential lighting project.

The smallest section linear system in the Radiant range, the Euclid 12 can provide up to 800 lumens per mtr.

The system incorporates the same medium power LED light engines used in the Shard so that the two systems can be used together. On board linear drivers and LEDs in a wide variety of colour temperatures with CRI up to 95.

Linear COB options are also available, allowing for dot-free linear lighting.

Opal or clear window versions are available.

The system can be supplied in any length up to 2.5 mtrs. Smallest cutting module based on 100 mm LED pitch.

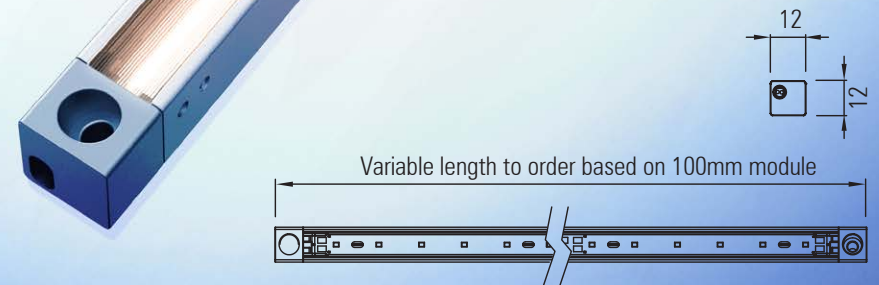

Up to 800 Lumens per mtr

# Euclid 20 Standard and High Output

## LED linear lighting system

The Euclid 20 system was originally developed with DPA in Dubai for use on residential projects as a simple to install, cost effective linear lighting system. The 16 Amp plug together connector system, which fits inside the body extrusion, allows up to 11 mtrs to be lit from a single feed point without dark gaps between strips.

Designed for use in both indirect cove lighting applications and also, with the addition of a linear lens and optical films, for wall grazing and wall washing.

The system incorporates the same medium power LEDs used in the Shard and Euclid 12 so that all these systems can be used together. The Euclid 20 system can produce up to 3,500 lumens per mtr from the High Output version.

A linear COB version is also available, giving dot-free lines of light.

RGBW and dynamic white light versions are also available.

Opal or clear window versions can be specified.

The system can be supplied in any length up to 2.5 mtrs with the smallest cutting module based on 100mm LED pitch.

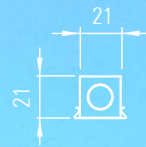

Up to 3.500 Lumens per mtr



Linear lens version - 40° beam angle



Dot-free version



Plug together connectors between strips which fit inside the modules for continuous lighting



Euclid 20 side feed



London Heathrow Airport, Terminal 2. Lighting design by Studio Fractal and Hoare Lea. Lux Award winner

# Euclid 20 Balljoint Standard and High Output

## Modular, 3D flexible LED linear lighting system

The Euclid 20 Balljoint system combines the simplicity of the Euclid 20 with the total flexibility of the 3D LED Flex range.

The system incorporates the same medium power LEDs used in the Euclid 20 so that these systems can be used together on the same project. On-board linear drivers and LEDs in a wide variety of colour temperatures with CRI up to 95. Up to 3,500 lumens per mtr. from the High Output version.

A linear COB version is also available, giving dot-free lines of light.

Opal, clear window and linear lens versions are available.

Modules in any length based on a 100 mm module can be used to make up complete lengths of the system. RGBW and dynamic white light engines can also be incorporated in this system.

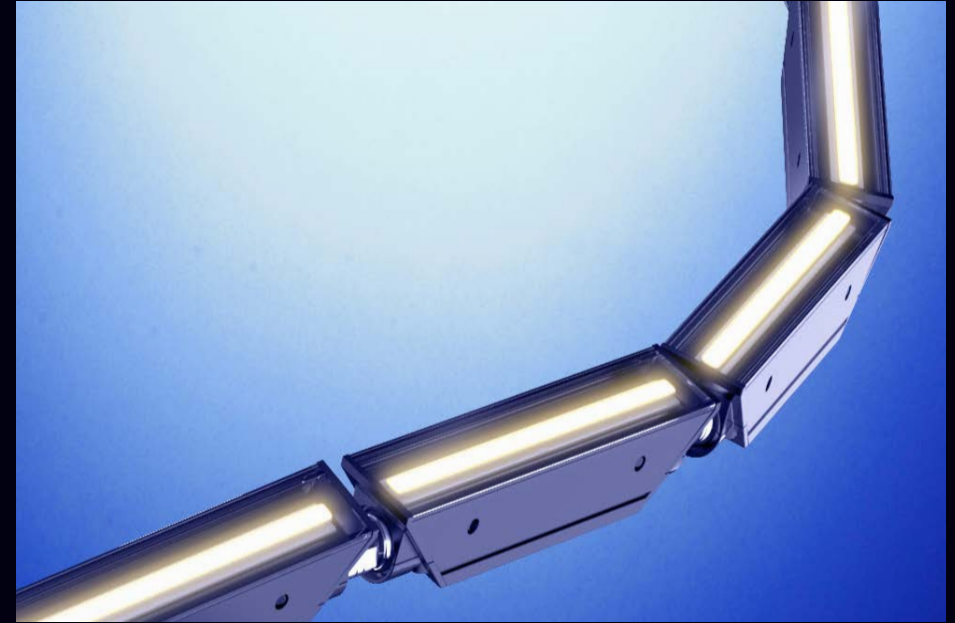
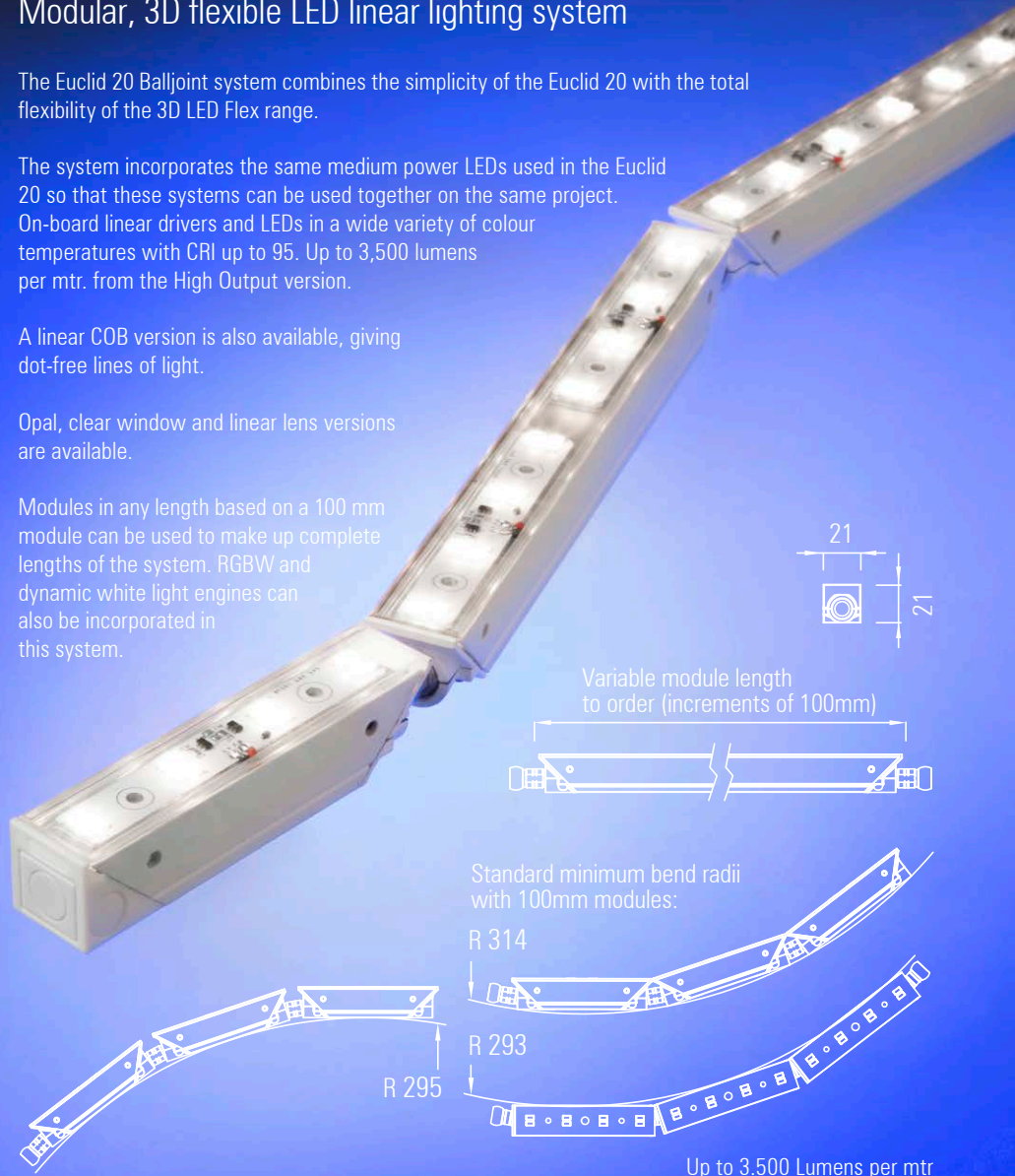

Linear COB version

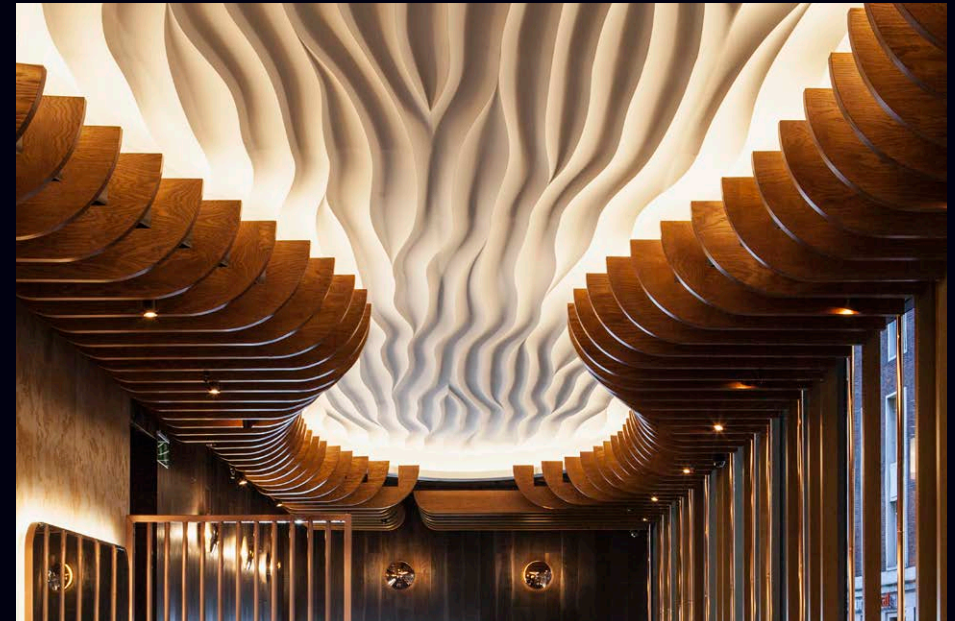

Haz Restaurant, London. Lighting design by Nulty. Shortlisted for Restaurant & Bar Design Awards, Lighting category

# Euclid 30 IP65

## Exterior LED linear lighting system

The Euclid 30 IP65 system can be used in a wide variety of exterior linear lighting applications including indirect cove lighting, wall grazing and wall washing.

The extruded body heat sink incorporates space for IP67 rated connectors so that up to 11 mtrs of the system can be linked together on site and fed from a single feed point without dark gaps.

The system incorporates the same medium power LEDs used in the interior Euclid systems. Up to 3,000 lumens per mtr. Opal, dot-free opal, clear window and linear lens versions are available. RGBW and dynamic white light engines can also be incorporated in this system.



Up to 3,000 Lumens per mtr

## Euclid 30 IP65 with anti-glare cover accessory



Anti-glare cover accessory:



Adjustable angle bracket:

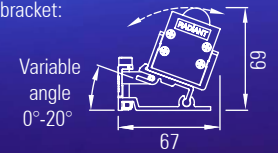

Variable length to order based on a 100mm module length

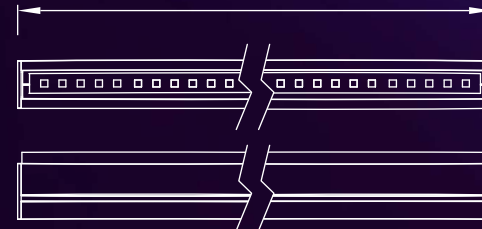

Fixed angle bracket





# Euclid 30 IP68

## Underwater IP68 LED linear lighting system

The Radiant Euclid 30 IP68 system is designed for use in underwater applications where linear lines of light are required. The system components are cast in 316 L stainless steel and are suitable for use in saline and chlorine environments, up to 2 mtrs in depth, including pools, fountains and marine projects.

The Euclid 30 modules incorporate the same LEDs and optics as the 3D LED Flex 25 IP68 so they can be used together on the same project. LEDs come in a wide variety of colour temperatures with CRI up to 95.

The system can produce up to 2,500 Lumens per mtr.



Up to 2,500 Lumens per mtr

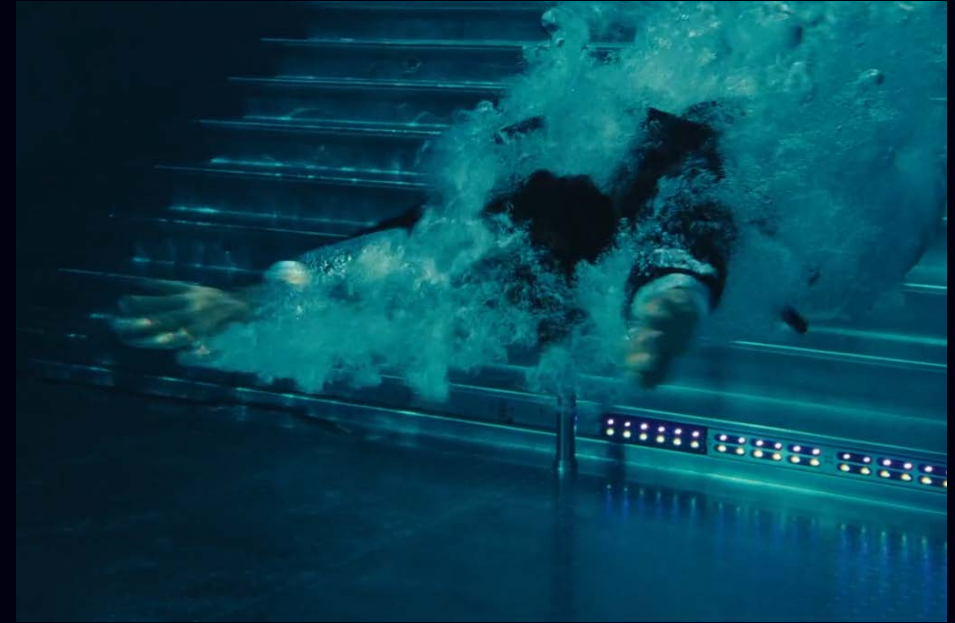

Sky Pool, Embassy Gardens, London. Lighting design by GIA Equation. Photography by Ballymore.



# Euclid 40 MP IP20 Standard and High Output

## LED linear lighting system

The Euclid 40 MP system has been developed for use in a wide variety of linear indirect lighting applications and is optimized for cove lighting.

The system incorporates the same medium power LEDs used in the Shard and other Euclid systems so that they can all be used together in the same space.

Linear COB light engines can also be incorporated for use with specular lit surfaces.

The profile and light output of the Euclid 40 matches the non lens version of the 3D LED Flex 40 so that they can be used in the same project to light linear and curved spaces.

Up to 5,500 lumens per mtr. Clear or opal window versions are available along with RGBW and dynamic white light versions.

The system can be supplied in any length up to 2.5 mtrs with the smallest cutting module based on a 50 mm pitch.

On board linear drivers with a remote power supply and separate dimming channel.

A line voltage version is also available.



Up to 5,500 Lumens per mtr



Blewberry Church, UK. Lighting design by Studio Melyn. Photography by Red Shift



Euclid 40 side feed



Euclid 40 end feed

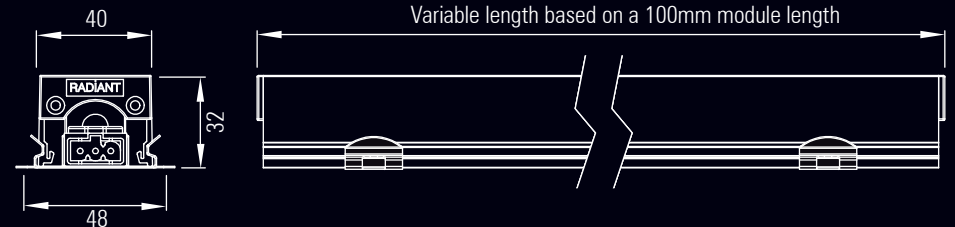

# Euclid 40 IP20 with lenses

## LED linear lighting system

The Radiant Euclid 40 system has been developed for use in a wide variety of linear direct and accent lighting applications including wall grazing, and wall washing. Very narrow lenses provide excellent wall grazing over long distances. The profile and light output of the Euclid 40 matches the lens version of the 3D LED Flex 40 so that they can be used in the same project to light linear and curved surfaces. Anti-glare louvres from the 3D LED Flex 40 can also be used with the Euclid 40.

The self-locking adjustable angle bracket allows precise aiming from the front.

Integral DC to DC LV drivers with a remote power supply, or a line voltage version is also available.

The system can be supplied in any length up to 2.5 mtrs with the smallest cutting module based on a 100mm LED pitch.



Up to 5,000 Lumens per mtr



Euclid 40 system with two-colour snoots

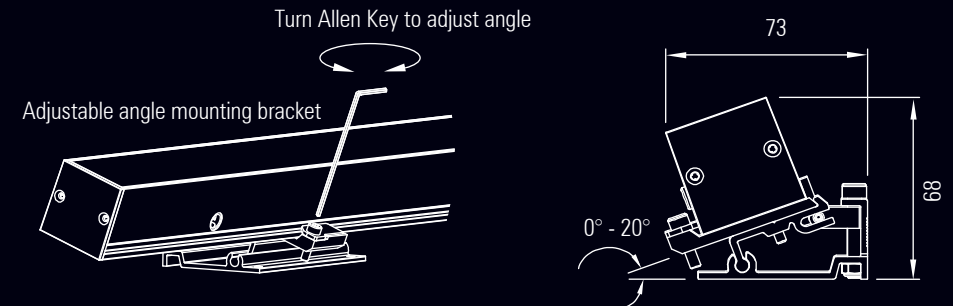
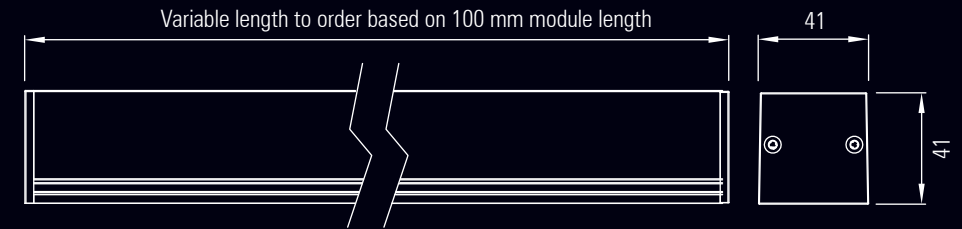

# Euclid 40 IP20 Vector

## Asymmetric LED linear lighting system

A custom designed asymmetric output version of the Euclid 40 was developed for the refurbishment of the David Geffen Hall at Lincoln Center for the Performing Arts in New York, in collaboration with lighting designers Fisher Marantz Stone.

In order to successfully illuminate the acoustically optimized undulating beech wood paneling of the auditorium walls luminaires with a strongly asymmetric output were required.

The custom Euclid 40 luminaires incorporate angled asymmetric lenses, anti glare louvres and a softening optical film to produce the optimal lit effect for the project.

Radiant self locking adjustable angle mounting brackets were included allowing vertical adjustment of individual luminaires.

Semi recessed and surface mounted versions of the luminaires were developed. All visible metal work was powder coated in a bespoke RAL powder coat, produced especially for the project, which matches the paint finish used for the project ensuring that the luminaires are as visually unobtrusive as possible.

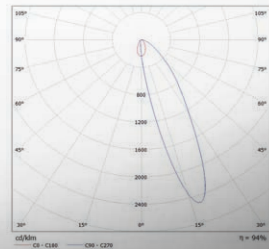

Up to 2,500 Lumens per 400mm luminaire



Surface mounted Euclid 40 Vector including housing  
Geffen Hall with semi recessed Euclid 40 Vector luminaires

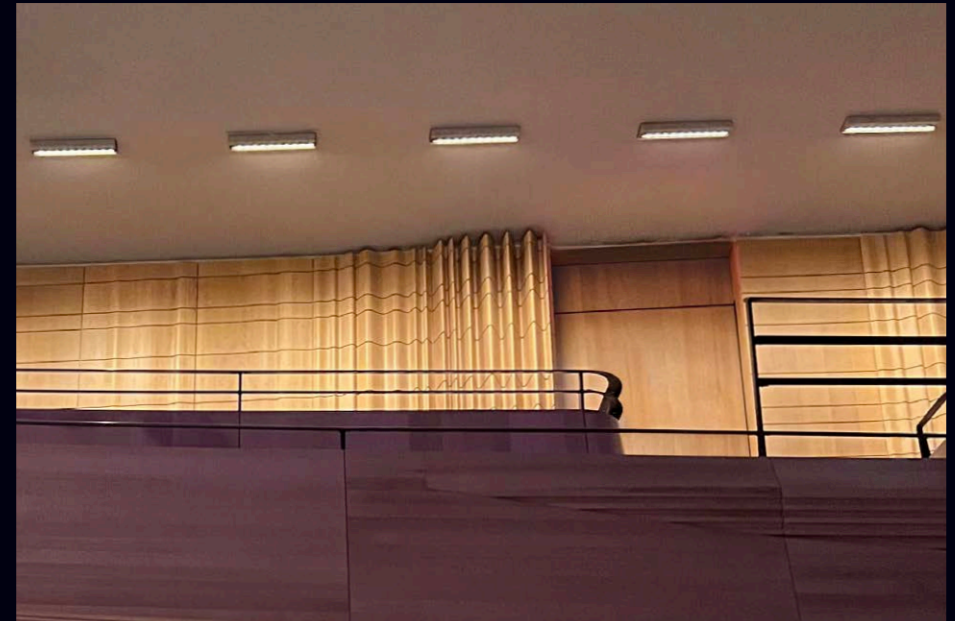

# Euclid 40 IP65 Standard and High Output

## Exterior LED linear lighting system

The Euclid 40 IP65 system has been developed for use in exterior indirect linear lighting applications.

The system incorporates DC to DC linear constant current drivers to ensure efficient LED operation and so that long lengths of the system can be run from a single large power supply thus reducing wiring and installation costs. The Euclid 40 system can provide up to 5,000 lumens per mtr.

The extruded heat sink profile design allows end, side or back power entry. The LED pitch is maintained between the individual luminaires to maintain constant lighting levels without dark areas.

The system can be supplied in any length up to 2.5 mtrs with the smallest cutting module based on a 100mm LED pitch.

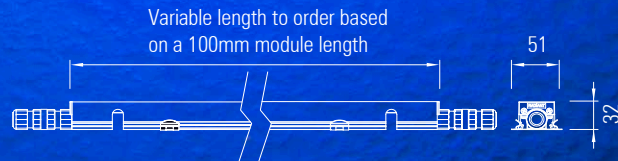

Up to 5,000 Lumens per mtr



Swindon Designer Outlet, UK. Architecture by McLaren & POD. Lighting design by Aecom  
Euclid 40 IP65 with lenses

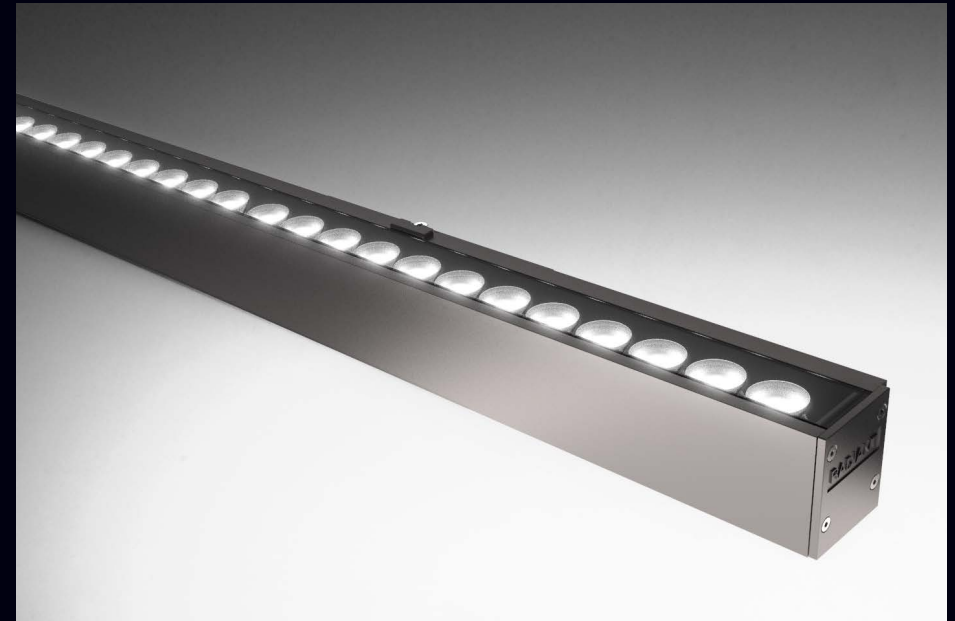

# Euclid 60 IP65

## Exterior LED linear lighting system

The Euclid 60 system has been developed for use in exterior linear lighting applications including wall grazing and wall washing. The system incorporates mains voltage dimmable drivers.

Side, back and end power feed options ensure continuous lighting without dark areas between luminaires.

The system can be supplied in custom lengths based on a 100 mm module up to 2.5 mtrs.

A variety of mounting bracket and glare control options are available including both micro and honeycomb louvres.

The system can be supplied in any RAL colour powder coat finish.

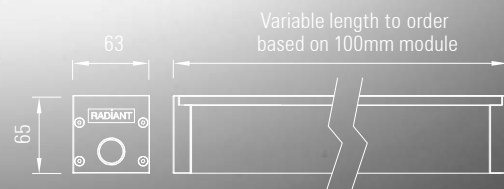

Up to 6,000 Lumens per mtr

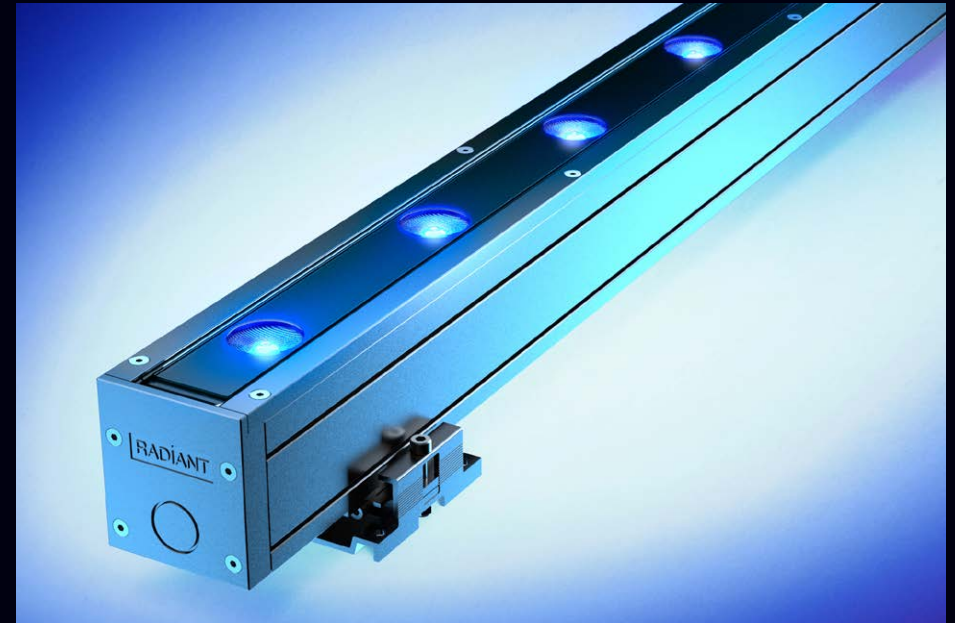

Euclid 60 IP65 RGBW with Gaggione's range of 32mm diameter colour-blending lenses  
Euclid 60 IP65 with mid-power LEDs, linear lens and micro-louvre



# Euclid 60 IP67 In-Ground

## Buried LED linear lighting system IP67

The Euclid 60 system has been developed for use in exterior wall grazing lighting applications. A high power optical system has been developed to produce an ultra narrow, dot free, line of light. Dark areas between luminaires are minimised with an innovative frame detail. A mid-power LED light engine with 3-ply opal diffuser is also available for wall washing applications. Anti-glare accessories are available.



Up to 6,000 Lumens per mtr

The Exchange, UK. Lighting design by MBLD

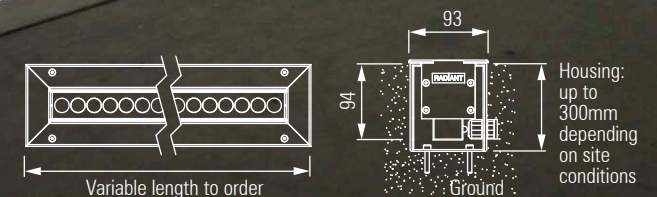
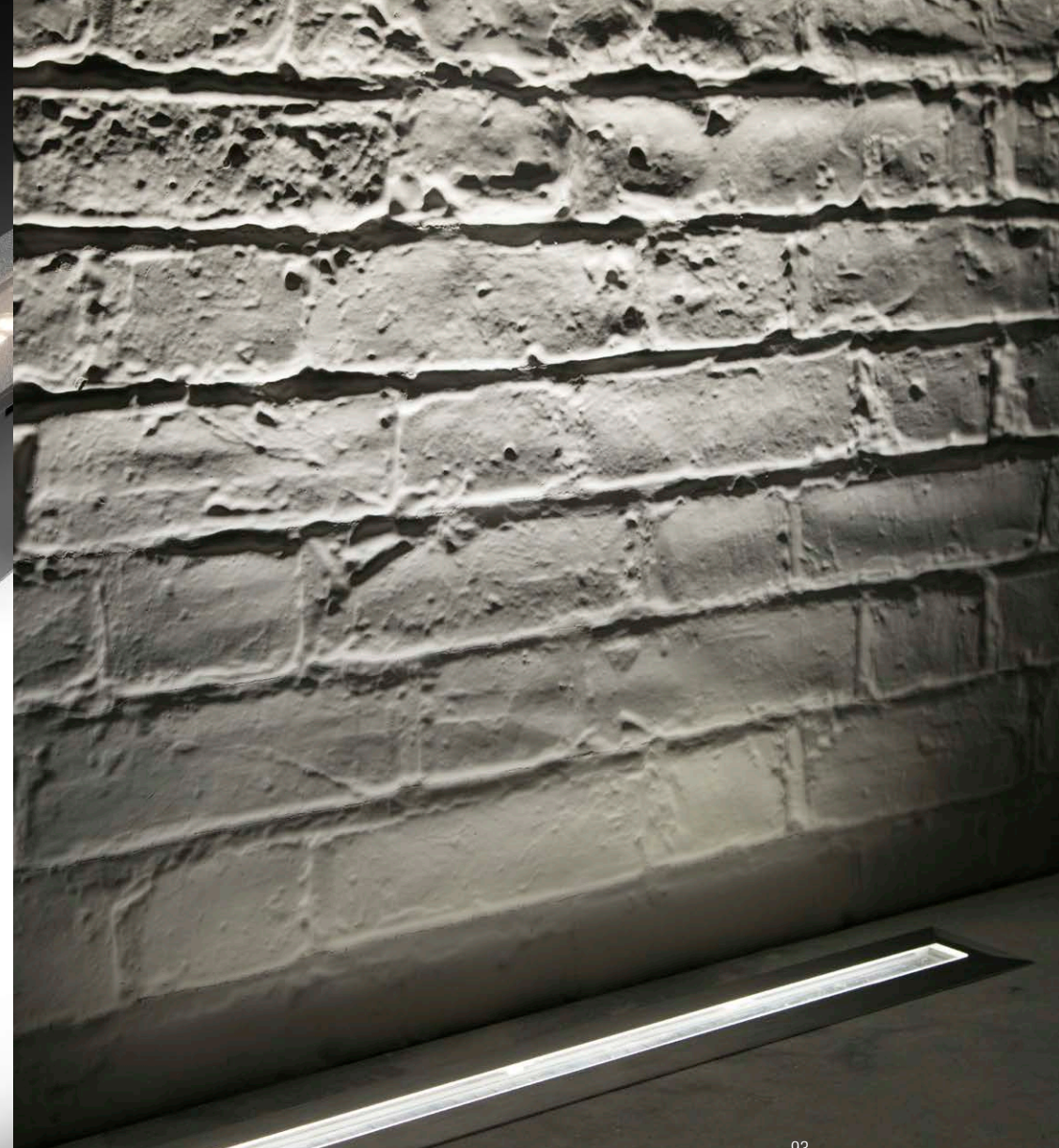

# Euclid 60 IP67 In-Ground

## Buried LED linear lighting system IP67

A project specific version of the Euclid 60 system was designed in collaboration with MBLD for the Quay Club in Canary Wharf, London. Matching in-ground IP68 and ceiling-mounted downlight IP66 versions were created.

The LED linear lighting system comprises of a high-output LED light engine and a custom 3-ply opal diffuser, which runs from end to end, providing long seamless lines of light with no gaps between individual luminaires. Custom right-angle corner luminaires were also created - ensuring that the single unbroken seamless line of light was able to follow the entire perimeter of the atrium.

The luminaires are installed into the stainless steel housings and held in place with spring clips. There are no visible fixings once installed - allowing the system to integrate into the architecture as unobtrusively as possible. The stainless steel trim has a mirrored finish, to match the mirrored ceiling of the building.

Integral line voltage AC drivers allow for ease of wiring. IP68 connectors join the fixtures on-site and fit neatly within the housing.



Mid-power LED light engine



Exploded view

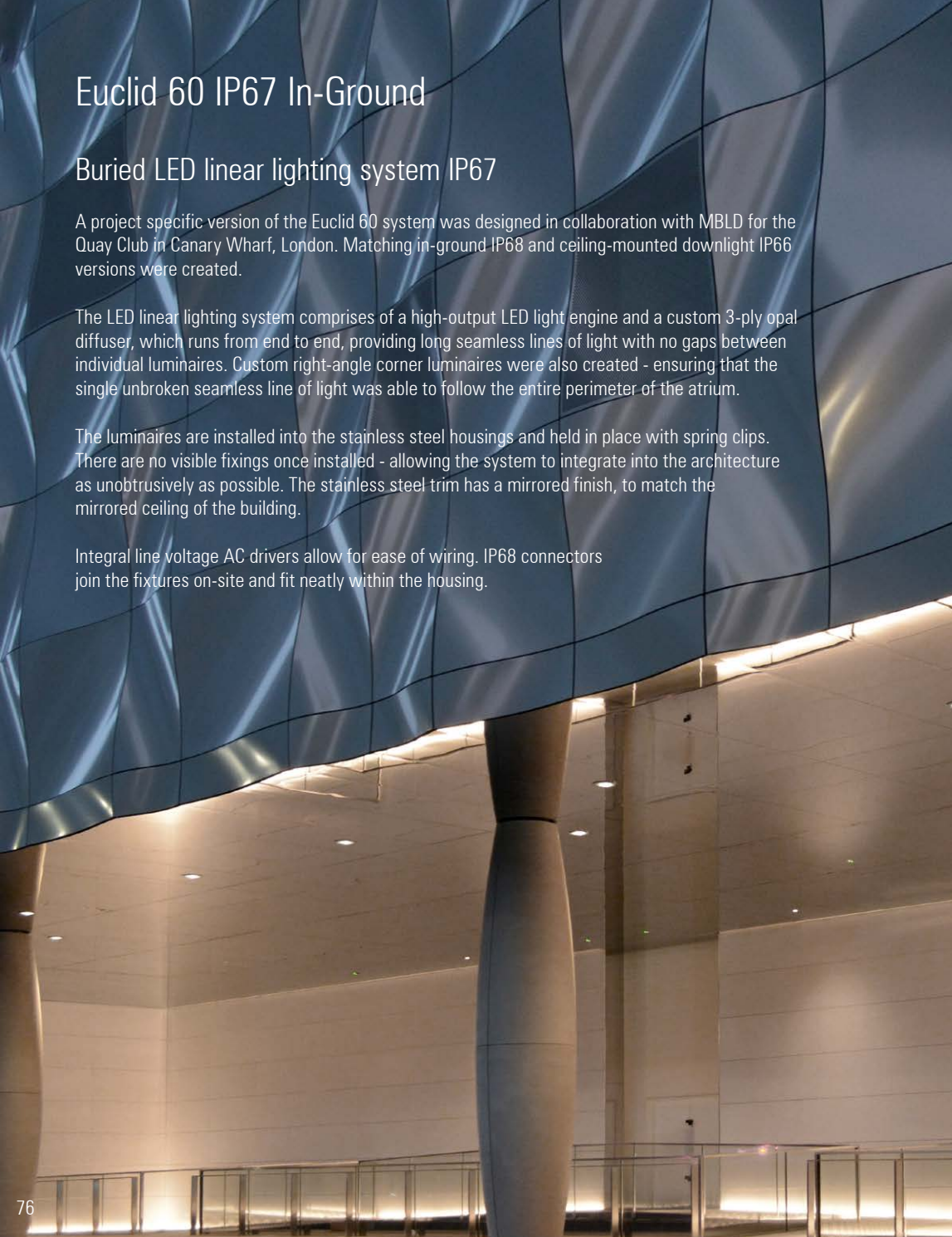

Quay Club, Canary Wharf, London. Lighting design and project photography by MBLD



## Euclid 80 IP65

### RGBW LED linear lighting system IP65

The Euclid 80 system has been developed for use in high power exterior linear RGBW architectural lighting applications including wall grazing and wall washing.

This system incorporates highly efficient colour blending Gaggione lenses giving high levels of RGBW, dynamic white or white LED output.

Integral or remote mains DMX / DALI drivers can be used.

The system can be supplied in custom lengths based on a 200 mm module up to 2.5 mtrs. A variety of mounting bracket and glare control options are available.

The Euclid 80 system can be supplied in any RAL colour powder coat finish.



Up to 8,000 Lumens per mtr

## Euclid 80 IP67 In-Ground

### RGBW Buried LED linear lighting system IP67

The Euclid 80 system has been developed for use in high power exterior linear RGBW architectural lighting applications including wall grazing and wall washing.

The in-ground luminaires are installed into the stainless steel housings and held in place with spring clips. There are no visible fixings once installed - allowing the system to integrate into the architecture as unobtrusively as possible.

The RGBW light engine comprises a series of Luxeon Z LED clusters each with an elliptical beam colour-mixing lens. The light engines can be angled towards the surface being illuminated.

AC to DC constant current dimmable drivers are housed within the body of the fixture, allowing for ease of installation and wiring. IP68 connectors join the fixtures on-site and fit neatly within the housing.

Anti-glare accessories, including a micro-louvre, ensure excellent visual comfort.



# Euclid 100 IP65

## Exterior LED linear lighting system IP65

The Euclid 100 system is the most powerful linear system in the range and has been developed for use in exterior linear high output architectural lighting applications including wall grazing and wall washing.

This system incorporates 2 parallel light engines with optics. By combining elliptical and wider beam angle lenses in the same luminaire extremely tall facades can be evenly lit.

The system incorporates dimmable line voltage drivers.

The system can be supplied in custom lengths based on a 200 mm module up to 2.5 mtrs.

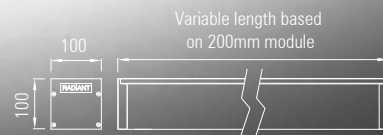

Up to 12,000 Lumens per mtr



Newfoundland Tower, London. Lighting design by MBLD



Euclid 100 IP65 with mid-power LED light engine and dot-free opal diffuser window

# Light Pipe

## RGBW LED linear lighting tube system

The Light Pipe system was developed with our Swedish distributor Rebel Light as a custom design for an atrium lighting project in Stockholm.

Long runs of linked high power RGBW light engines illuminate the sections of frosted acrylic diffuser.

A structural spine heat sink incorporates plug and play cable management for the light engines for ease of installation and servicing.

The system can incorporate a wide variety of LED light engines with white, dynamic white or RGBW LED arrays.

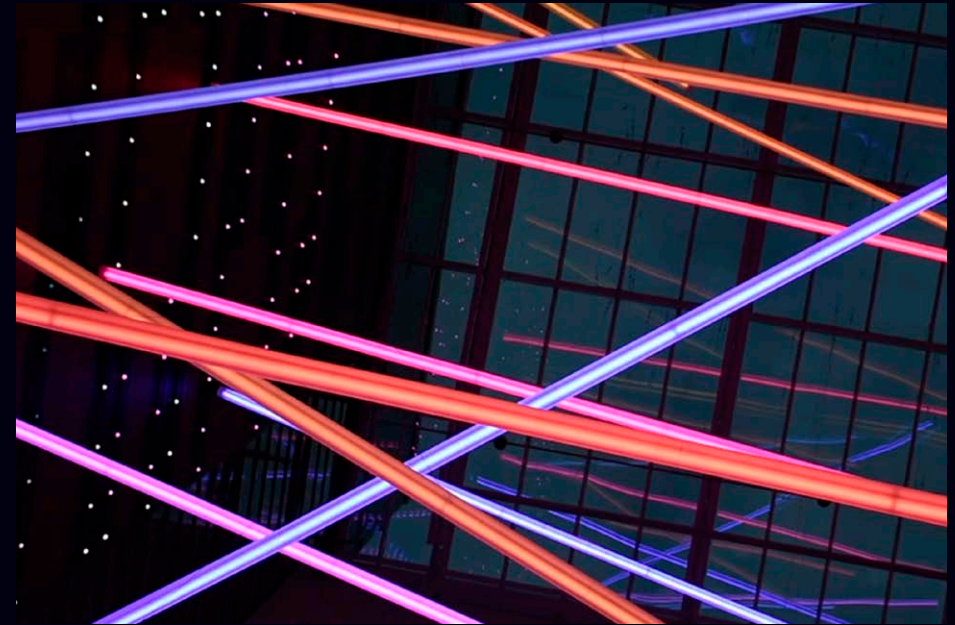
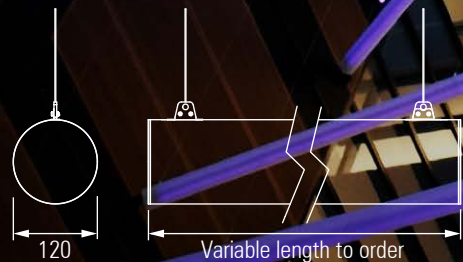

Telia headquarters, Sweden. Lighting design by ÅF Lighting

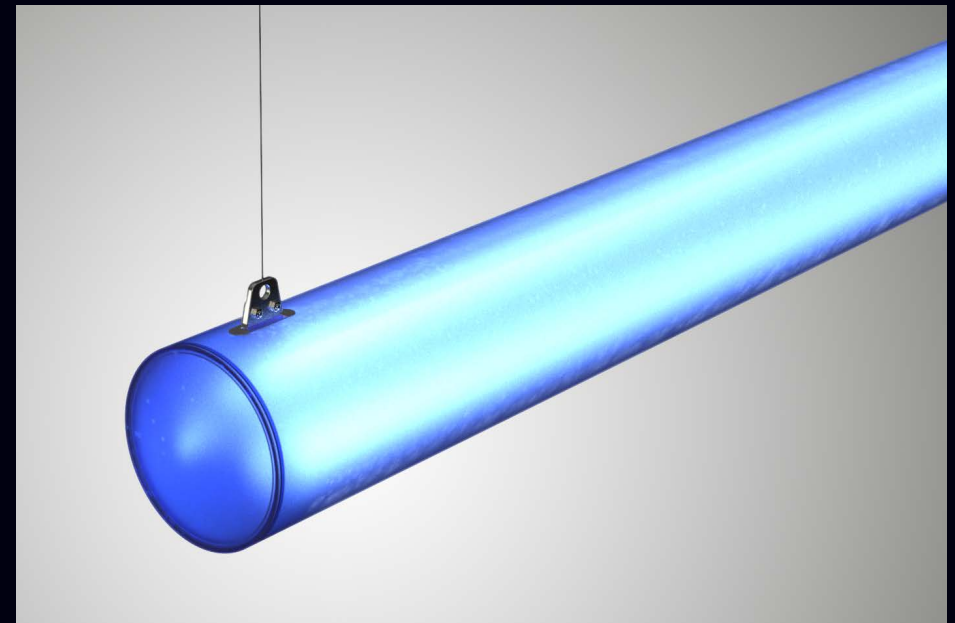

# Micro Track System



The Radiant LED Micro Track is one of the smallest section low voltage track systems available and is designed for use in retail display, museums and residential lighting applications.

The range of dimmable miniature spotlights can be fitted with a wide range of anti-glare and light control accessories.

The light output from the Radiant LED spotlight range contains very little heat or UV. The system is ideal for the illumination of sensitive materials.



Nano LED Spotlight. Up to 2.5 Watts



Mini LED Spotlight. Up to 6.5 Watts



Cone LED Micro Spotlight. Up to 4.5 Watts



Ribbed LED Micro Spotlight. Up to 4.5 Watts



MR16 LED Snap Spotlight. Up to 8 Watts



Micro Spotlight on 50mm surface mount base



In-line connectors



End cap and fixing clip with black and chrome track

# Micro Track System

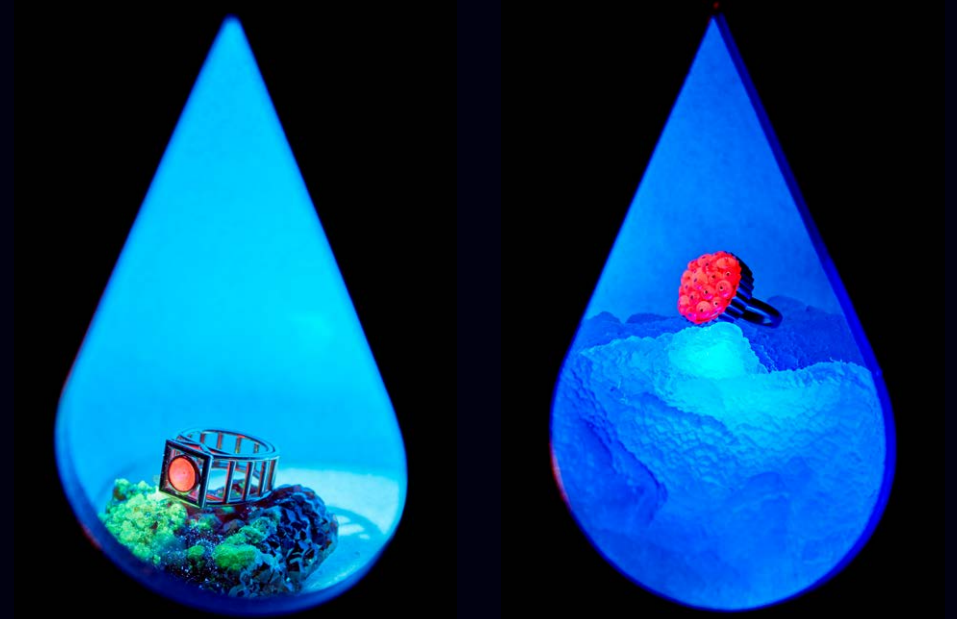
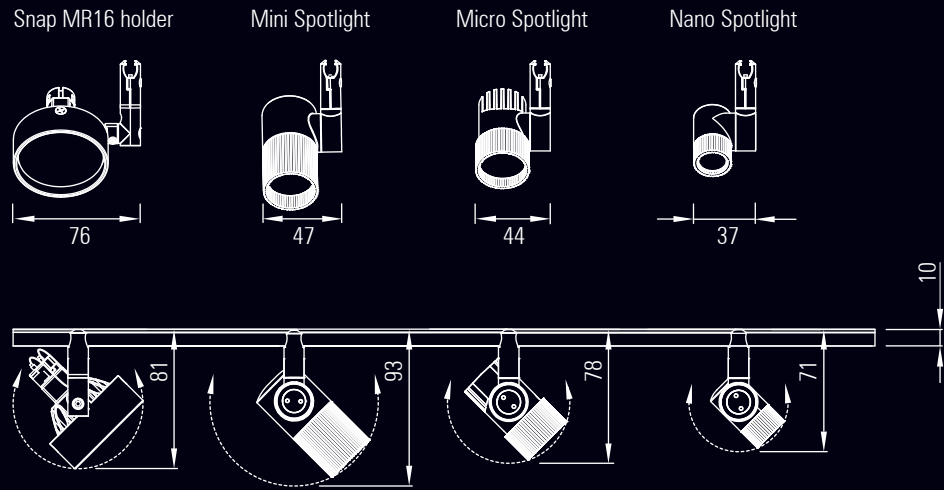

Louisa Guinness gallery, London. Glow by Cora Shebani. Jewels with Fluorescence - with UV Nano Spotlights



Harrods department store, London. Lighting design by BDP

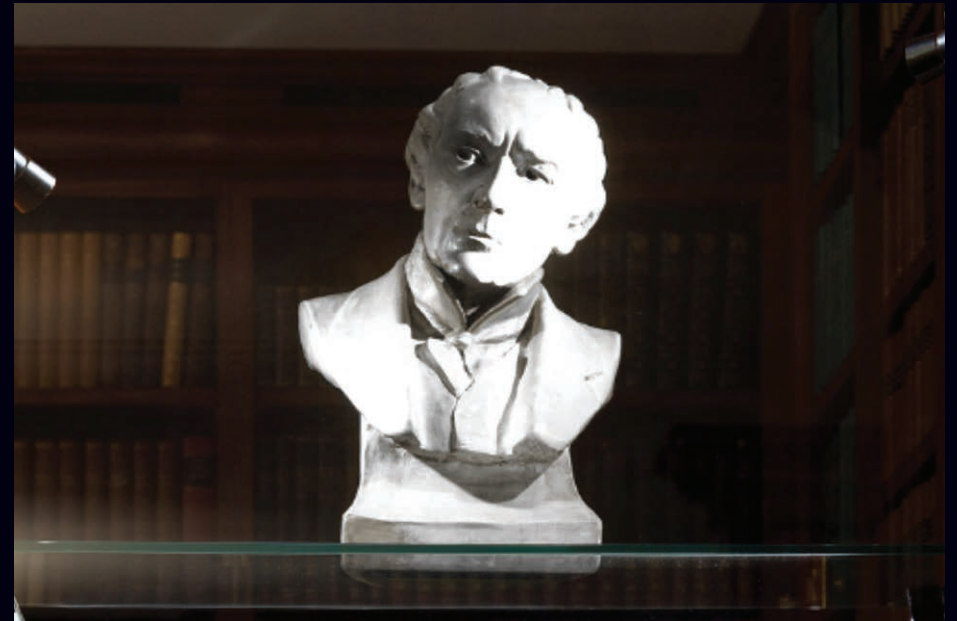

Garrick Club, London. Lighting design by BDP

## Micro egg pendant range

### Interior optical LED pendant system

The micro egg pendant is designed for use in retail, hospitality and residential projects. A range of TIR optics allow for highly controllable directional accent lighting effects. The customisable LED light engine can be run at up to 2W providing up to 250 Lumens. Dim to warm and very low colour temperature LED options are available. Any anodized or RAL powder coat finish and a range of decorative cable options are available. Pendants can be suspended from either Radiant's LV Micro Track (see previous pages) or an individual surface mount base can be used. The light output contains very little heat or UV making it ideal for the illumination of sensitive materials.

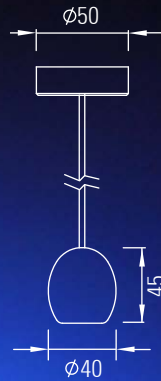

GERMAN  
DESIGN  
AWARD  
WINNER  
2019

Up to 250 Lumens per pendant

## Nano, Micro, & Macro Ribbed pendants

### Interior optical LED pendant system

The Ribbed Pendant range incorporates the same optics and LV DC to DC dimmable drivers as the Micro Track and Aleta spotlight range so they can be used together in the same projects. Three diameters are available in custom lengths with any anodized or powder coat colour finish. A range of decorative cables are available. The ribbed pendants are designed for use in hospitality, retail, residential and architectural lighting applications. Gaggione colour-blending lenses can be incorporated into the Macro size, so that perfectly mixed RGBW and Tunable-white lighting effects with highly controlled beams, including an ultra-narrow beam option, can be created.

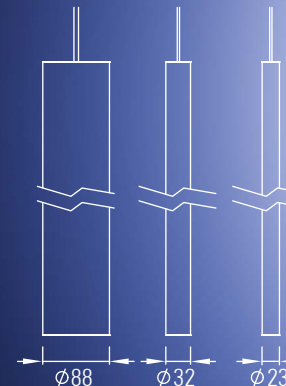

Macro Pendant: Up to 10 W  
Micro Pendant: Up to 7.5 W  
Nano Pendant: Up to 4.5 W

# Magnetic Low Voltage Track

## Interior magnetic LV track and spotlight system

The magnetic track system allows very easy installation and movement of the Radiant LED spotlight range.

Separate track circuits for low voltage power and dimming ensures excellent dimming control with all protocols.

Ideal for retail, museum and hospitality lighting applications where luminaires need to be re-positioned on a regular basis without specialist technical help.



Magnetic track with Nano Spotlight



Magnetic track with Snap MR16 Spotlight

Snap MR16 holder

Mini Spotlight

Micro Spotlight

Nano Spotlight

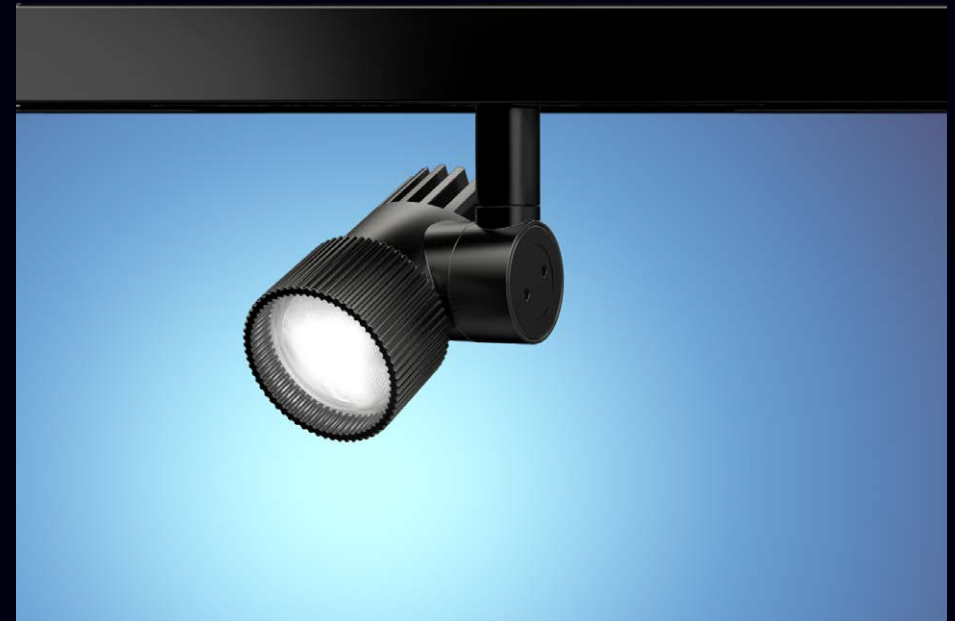
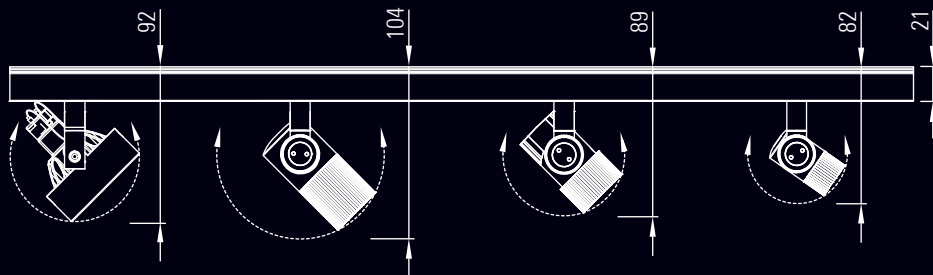
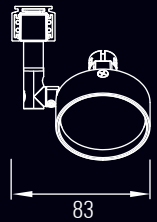

Magnetic track with Micro Spotlight

# Global Track

## Line voltage three circuit track and LED spotlight system

The popular line voltage Global Track System is ideal for use in retail and gallery display applications. The range of Radiant LED spotlights mounted on the low profile track adapter with integral drivers provides a flexible and elegant solution.

The Spotlight ranges available for the Global track includes the AR111 Spotlight with Soraa light engine and the D100 Spotlight with 11 Watt Citizen COB. A wide variety of optics and anti-glare accessories including honeycomb louvres can be incorporated in this range.

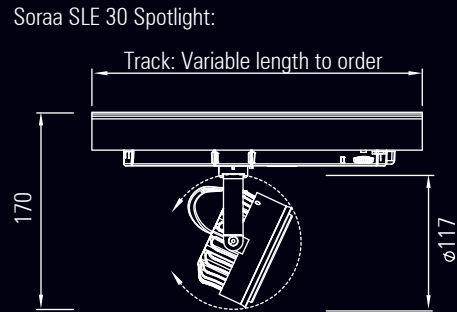
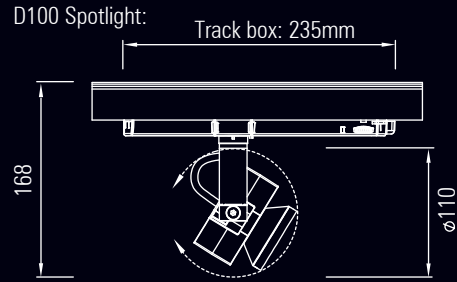

Global Track with D100 Spotlight



Global Track with Snap MR16 spotlight



Global Track with Soraa AR111 Spotlight



Global Track with Aleta 25 Watt Spotlight



# D100 IP20

## LED spotlight range IP20

The D100 range was originally developed for use in the relighting of Hereford Cathedral in conjunction with Light Perceptions. A low profile and excellent glare control were required for this project to ensure that the spotlights were as invisible as possible. There are integral and remote driver versions with one, two or three spotlights per luminaire. A wide variety of anti-glare, beam control and colour filter accessories are available. They are fully lockable in both axes.

Up to 1,000 Lumens per spotlight

Remote driver version:

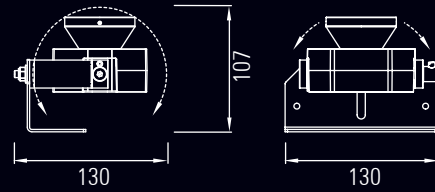

Integral driver version:

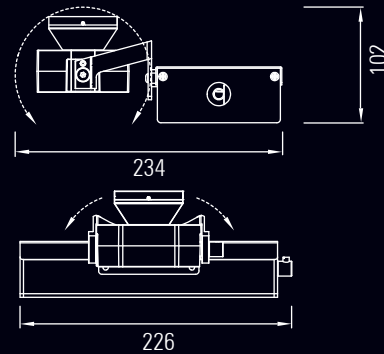

Hereford Cathedral, UK. Lighting design by Light Perceptions



D100 IP20 integral driver version with two spotlight heads

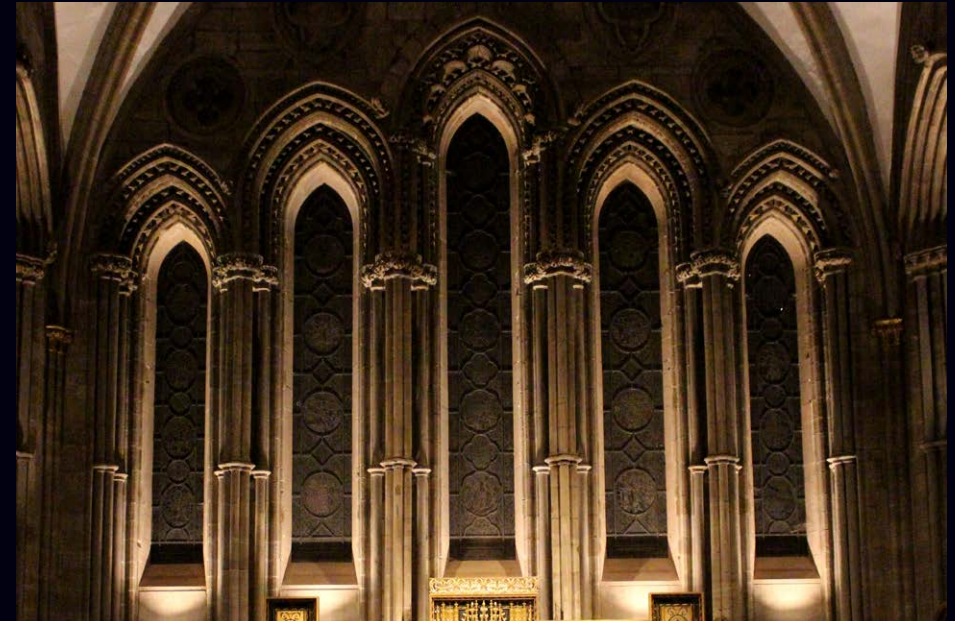

## D100 IP20 Split RGB

LED spotlight range IP20 with separate RGB spotlights

A custom version of the D100 Spotlight IP20 was designed in collaboration with Fabio A P Cristini at There's Light to create a triple colour shadow effect for the BLOK Shoreditch gym in London.

Three spotlight heads, each with different colour LEDs, are mounted to a driver box. Each one comprises 4 x high power LEDs with elliptical Ledil Tina lenses. They can be run at up to 11 Watts each.

Objects which are placed in front of them cast a 3 colour shadow onto the wall behind.



BLOK Shoreditch gym, London.  
Lighting design by Fabio A P Cristini at There's Light

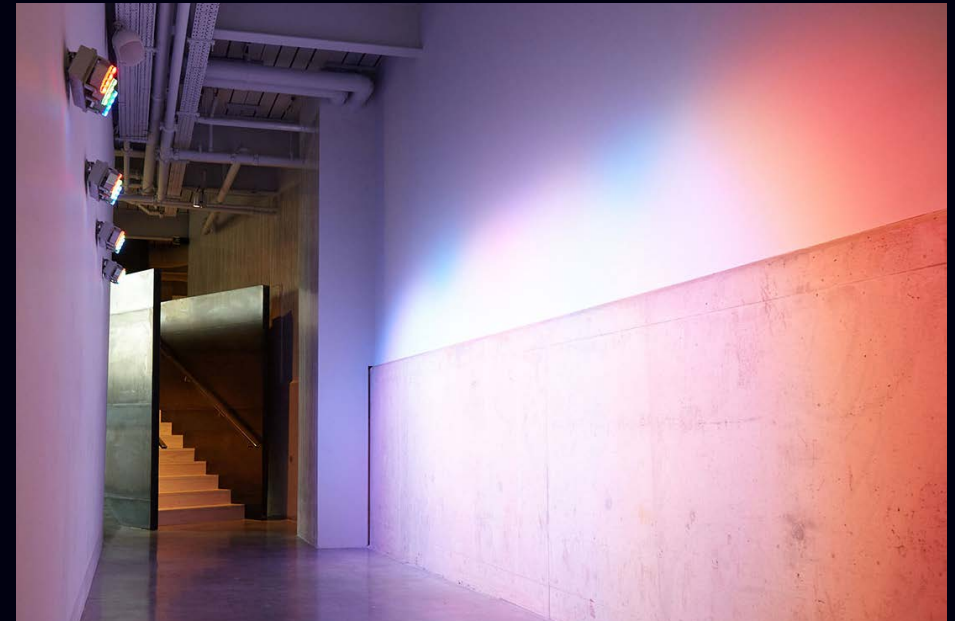

# D100 IP66

## LED accent lighting range IP66

The Radiant D100 system has been developed for use in a wide variety of exterior architectural lighting projects requiring highly controlled accent lighting effects from a compact luminaire.

The D100 can operate up to 11 Watts of LEDs, giving a light output of up to 1,000 Lumens. Various LED types and optical configurations are available including RGBW, RGBA and Tunable-white light options.

Gaggione's ultra-narrow beam colour-blending lens provides a 6 degree beam when used in conjunction with a cluster array of RGBW or Tunable-white LEDs.

Integral LV DC to DC driver and remote AC to DC driver versions are available.

A variety of mounting options and anti-glare accessories are available.



Up to 1,000 Lumens

Arnhem, Netherlands. Lighting design and project photography by Atelier LEK

Custom versions of the D100 IP66 spotlight system were created in collaboration with Atelier Lek for the master lighting renovation project for the city of Arnhem in Holland. Custom bracketry allow the spotlights to be mechanically integrated into the masts, which were designed and commissioned by Atelier Lek specifically for this project. The brackets allow the spotlights to be rotated and aimed, whilst maintaining a compact form factor. The spotlights comprise of a high power LED light engine with a narrow beam Gaggione lens, which provides highly controlled accent lighting used to illuminate the historic former Post Office building and other architectural highlights around the city centre. Each spotlight can be run at up to 11 Watts, providing up to 1,000 lumens.

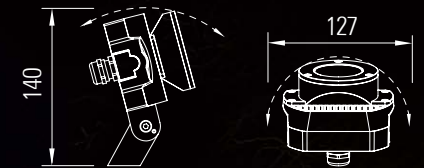

# D100 IP66

## LED accent lighting range IP66

The D 100 projector is now available with an ultra-narrow 4° lens.

Each D 100 projector can be run at up to 10 Watts, producing up to 800 Lumens with white LEDs.

Anti-glare accessories including customisable snoots can be specified, ensuring excellent visual comfort.

Both integral LV DC to DC driver and remote AC to DC driver versions are available.

Dimming options include 1-10 V, DMX and DALI.

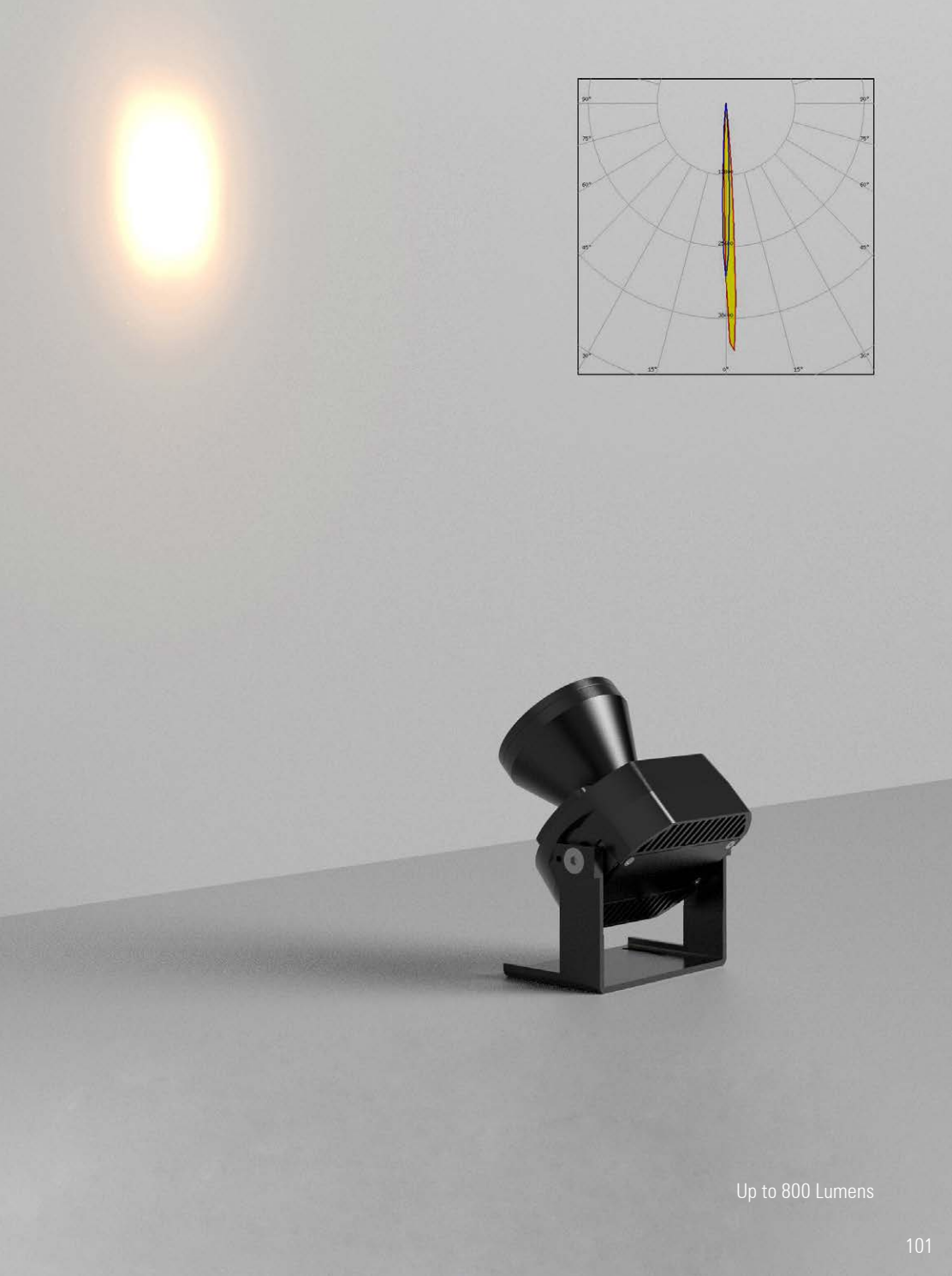

Up to 800 Lumens

# D40 IP66

## LED accent lighting range IP66

The Radiant D40 system has been developed for use in a wide variety of exterior architectural lighting projects requiring highly controlled accent lighting effects from a compact luminaire. The D40 can operate up to 5 Watts of LEDs, giving a light output of up to 500 Lumens. Various LED types and optic configurations are available including RGBW, RGBA and Tunable-white light options. An ultra narrow beam lens can produce a 4° beam. Integral LV DC to DC driver and remote AC to DC driver versions are available. A variety of mounting options and anti-glare accessories are also available, making this a highly versatile system.



Strasbourg Cathedral, France. Lighting design by Acté Lumière.  
Darc Award Winner - Structures- Best Exterior Lighting Scheme, High Budget

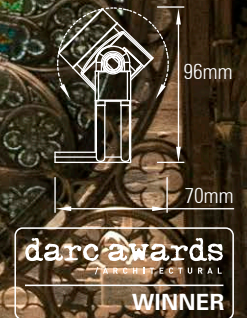

# Centura module IP20

## LED accent lighting range IP20

The Radiant Centura module IP20 system has been developed for use in a wide variety of architectural lighting projects requiring highly controlled accent lighting effects from a compact luminaire. The Centura module system can be used as wall-lights with up light, down light or up and down light options. Opal diffuser for ambient lighting, or lensed options for wall grazing can create the perfect lit effect to meet the project requirements. The Centura 40 module, which is 100mm in length, or the longer Centura 40 150 module, which is 150mm in length, have a slim profile of 40mm. The larger 60mm wide Centura 60 module, which is 100mm in length, can be specified for projects which require a 45mm diameter Gaggione colour-blending lens. This allows for perfectly blended RGBW and Tunable-white outputs in a range of beam angles, including narrow 8 degree and narrow-elliptical beam options. Centura modules can also be specified as downlight ceiling mounted fixtures. The Centura 40 150 module system can operate up to 7.5 Watts of LEDs per module, giving a light output of up to 800 Lumens. Various LED types and optic configurations are available. Integral LV DC to DC driver and remote AC to DC driver versions are available. Any colour RAL powder coat finish can be specified. Custom mounting solutions can be specified.

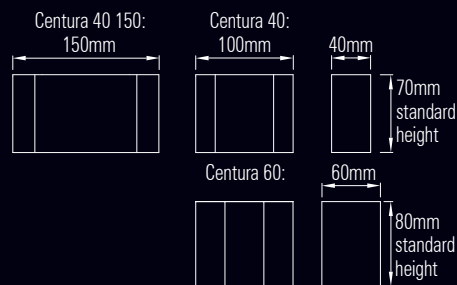

Centura 40 with optics - surface mount - cut-angle  
Centura 40 with optics - up & down wall-light



Centura 60 RGBW - wall light - down light  
Centura 40 with diffuser - up & down wall-light



Centura 60 RGBW - ceiling light - down light  
Centura 40 150 with diffuser - up & down wall-light

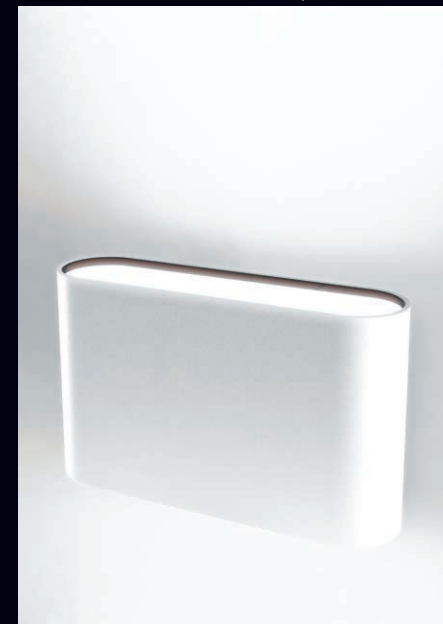

# RAD 250 IP68

Buried and submersible  
uplights



Regent's Place, London, RIBA award winner  
Lighting design by MBLD, Architects Carmody Groarke

Up to 3,000 Lumens per uplight

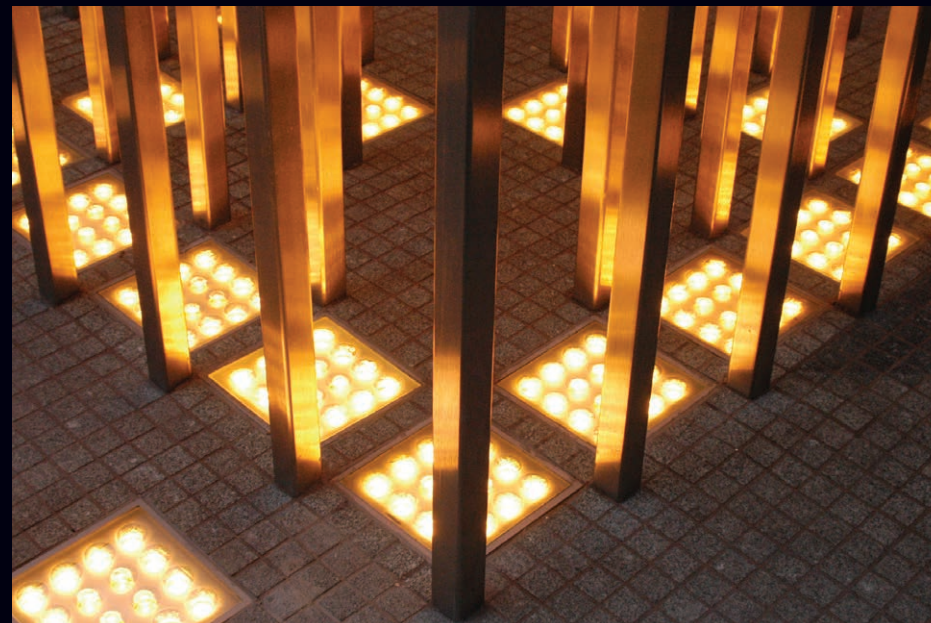

Regent's Place detail



RAD 250 buried uplight IP68 with 16 x high power LEDs with lenses



RAD 250 submersible uplight IP68 with 16 x high power LEDs with lenses

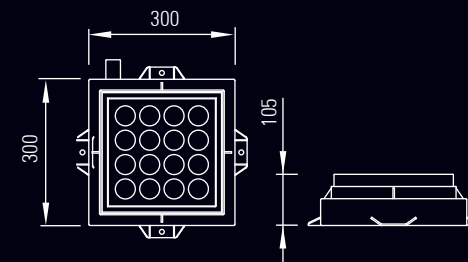
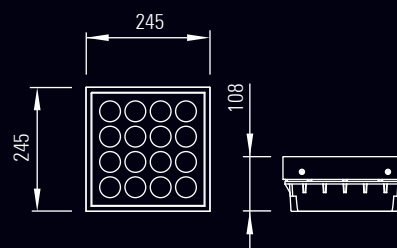

## Water Effect Lighting system

DMX controlled, dynamic LED effect light, IP20 and IP65

The Water Effect system was developed with ÅF Lighting for the Landmarket residential tower block project in Stockholm.

The surface mounted luminaires create a slowly changing effect of light reflected from flowing water.

A wide range of LED colour temperatures and coloured LED options can be incorporated in this system. Combining multiple LEDs with different textured glass panels and a 4 channel DMX controller creates unique lighting effects which can be customized for each project.

Light output up to 1,900 lumens with all LEDs on full power.

The system is available in IP20 and IP65 versions and the enclosures can be powder coated in any RAL finish.

There are currently two sizes available: a 150mm length version and a 300mm length version.

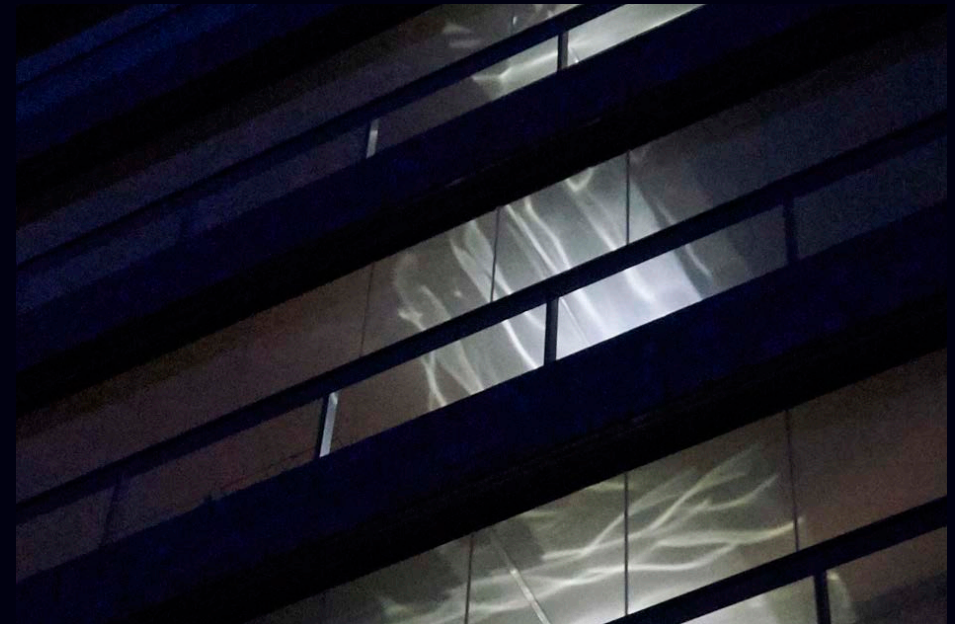
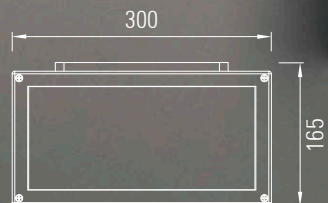
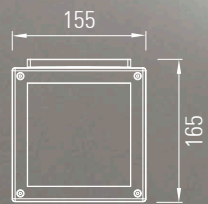

Landmärket residential tower, Stockholm. Luminaire concept and lighting design by ÅF Lighting



## Water Effect Lighting system

DMX controlled,  
dynamic LED  
effect light,  
IP20 and IP65

Zenisk specified Radiant 150 IP 65 Water Effect Lights to produce a gently changing lit effect, reminiscent of a gently flickering lantern, in a set of bespoke stainless steel bollards for the Sandvika river promenade development in Bærum, in Oslo.

Each bollard incorporates a customised Radiant 150 IP 65 Water effect luminaire with a matrix of LEDs of varying colour temperatures and an integral DMX controller.

The dynamic light output illuminates the custom pieces of decorative crystal-glass made by local glass makers, Hadeland Glassverk.

The Sandviksykta project luminaires won a Nordic Lighting Design Award in the category of best special product for a project in 2020.



Exploded view

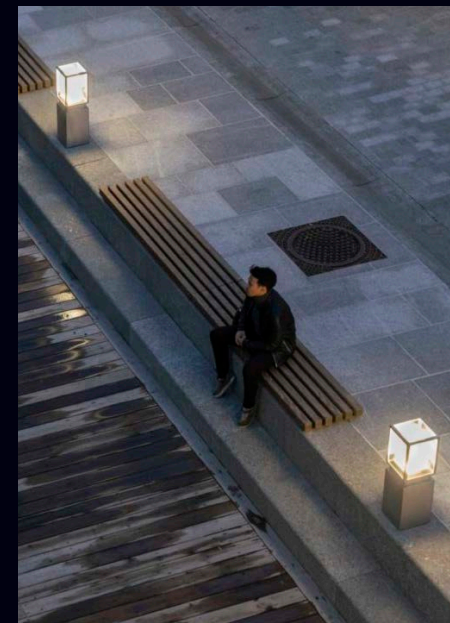

Sandviksykta, Norway. Lighting design & luminaire design by Zenisk. Photos by T.Majewski, Fovea Studio.

## Water Effect In-ground RAD 250 WE and RAD 180 WE

DMX controlled, dynamic LED  
effect light, IP20, IP66 and IP67

The in-ground version of the Water Effect system has developed the concept to a higher power level with multiple groups of LEDs and DMX control channels. Combining a variety of LED colour temperatures and colours with textured glass and complex dimming sequences creates abstract light patterns that can be customized for each project. The luminaires are durable with a walk over rated glass window, provide up to 3,500 lumens and as there are no moving parts, will provide a long working life. 255 mm and 180 mm diameter luminaires are available with a depth of only 100 mm for some versions.

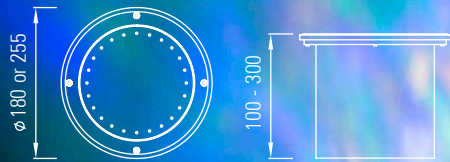

W Algarve, Portugal. Lighting design by MBLD

## Water Effect Linear

DMX controlled, dynamic LED  
effect light, IP20, IP66 and IP67

The linear in-ground version of the Water Effect system illustrated here utilises multiple LED groups and DMX channels combined with a custom linear prismatic optic to create gently changing sequences of light rays.

The system can be supplied for use in interior indirect cove lighting applications in an IP20 enclosure or in an IP rated enclosure for exterior wall washing.



W Algarve, Portugal. Lighting design by MBLD

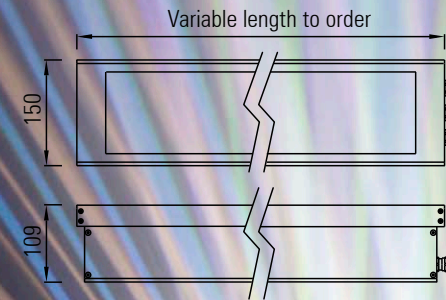

# RADIANT

ARCHITECTURAL LIGHTING

Radiant Architectural Lighting Limited  
10 Broadbent Close  
20 - 22 Highgate High Street  
London N6 5JW  
ENGLAND UK

TEL + 44 ( 0 ) 20 8348 9003  
FAX + 44 ( 0 ) 20 8348 6478

E MAIL [enquiries@radiantlights.co.uk](mailto:enquiries@radiantlights.co.uk)

WEB [www.radiantlights.co.uk](http://www.radiantlights.co.uk)

For updates about our latest products, projects  
and other news, follow us on social media:

 [facebook.com/radiantlightsuk](https://facebook.com/radiantlightsuk)

 [twitter.com/radiantlightsuk](https://twitter.com/radiantlightsuk)

 [uk.pinterest.com/radiantarch](https://uk.pinterest.com/radiantarch)

 [instagram.com/radiantarchitecturallighting](https://instagram.com/radiantarchitecturallighting)

 [youtube.com/@radiant.lights](https://youtube.com/@radiant.lights)